

# Traffic Signs Manual

CHAPTER

# 4

Warning Signs  
2013

# Traffic Signs Manual

## Chapter 4

### Warning Signs

Department for Transport

Department for Regional Development (Northern Ireland)

Scottish Government

Welsh Government

London: TSO

## Contents of Chapters 1-8

- CHAPTER 1** Introduction
- CHAPTER 2** Informatory Signs \*
- CHAPTER 3** Regulatory Signs
- CHAPTER 4** Warning Signs
- CHAPTER 5** Road Markings
- CHAPTER 6** Illumination of Traffic Signs \*
- CHAPTER 7** The Design of Traffic Signs
- CHAPTER 8** Traffic Safety Measures and Signs for Road Works and Temporary Situations

\* To be published

Published with the permission of the Department for Transport on behalf of the Controller of Her Majesty's Stationery Office.

© Crown copyright 2004 and 2013

Copyright in the typographical arrangement rests with the Crown.

You may re-use this document/publication (not including logos) free of charge in any format or medium, under the terms of the Open Government Licence. To view this licence, visit <http://www.nationalarchives.gov.uk/doc/open-government-licence> or write to the Information Policy Team, The National Archives, Kew, Richmond, Surrey TW9 4DU; or email: [psi@nationalarchives.gsi.gov.uk](mailto:psi@nationalarchives.gsi.gov.uk).

ISBN 9780115532245

First published 1980

Fourth edition 2013

Printed in the United Kingdom, for TSO, using material containing 100% post-consumer fibres, FSC® Recycled certified and PCF (Process Chlorine Free)

J2669080 C5 07/13

# Traffic Signs Manual

## Chapter 4

### CONTENTS

|   |    |
|---|----|
| 1. INTRODUCTION                                       | 4  |
| 2. JUNCTIONS  | 10 |
| 3. DEVIATION OF ROUTE                                 | 14 |
| 4. ROAD NARROWS                                       | 19 |
| 5. TWO-WAY TRAFFIC AND DUAL CARRIAGEWAY ROADS         | 22 |
| 6. HILLS  | 27 |
| 7. BRIDGES AND OTHER STRUCTURES                       | 29 |
| 8. TRAFFIC SIGNALS                                    | 41 |
| 9. PEDESTRIANS  | 43 |
| 10. ANIMALS AND FARM TRAFFIC                          | 46 |
| 11. WATER   | 50 |
| 12. ROAD SURFACE                                      | 52 |
| 13. ROAD HUMPS  | 54 |
| 14. LOW-FLYING AIRCRAFT                               | 56 |
| 15. FALLING OR FALLEN ROCKS                           | 57 |
| 16. HAZARD MARKERS                                    | 58 |
| 17. OTHER DANGER                                      | 59 |
| 18. DISTANCE PLATES                                   | 60 |
| 19. MISCELLANEOUS HAZARDS                             | 61 |
| 20. SLOW-MOVING VEHICLES                              | 62 |
| 21. LEVEL CROSSINGS                                   | 64 |
| 22. CYCLING   | 71 |
| 23. REFUGE BEACON                                     | 72 |
| APPENDIX A: Sizes of warning signs and siting details | 73 |
| APPENDIX B: Sizes of supplementary plates             | 76 |
| APPENDIX C: Variation of numerals                     | 79 |
| APPENDIX D: Schedule of diagram numbers               | 82 |
| INDEX   | 85 |

---

# 1 INTRODUCTION

---

## GENERAL

**1.1** The Traffic Signs Manual is intended to give advice to traffic authorities and their agents on the correct use of signs and road markings. Mandatory requirements are set out in the current version of the Traffic Signs Regulations and General Directions; nothing in the manual can override these. The advice is given to assist authorities in the discharge of their duties under section 122 of the Road Traffic Regulation Act 1984, but it is for traffic authorities to determine what signing they consider necessary to meet those duties.

**1.2** The Traffic Signs Manual is applicable in England, Northern Ireland, Scotland and Wales. References to “the Secretary of State” should therefore be interpreted as referring to the Secretary of State for Transport, the Department for Regional Development (Northern Ireland), the Scottish Government or the Welsh Government as appropriate.

**1.3** Any reference to a “Chapter” is a reference to a Chapter of the Traffic Signs Manual, and any reference to a “section”, unless otherwise stated, is a reference to a section in this chapter of the Manual. Where more detailed background information might be helpful, reference is made to Standards and Advice Notes in the Design Manual for Roads and Bridges, available from TSO or [www.dft.gov.uk/ha/standards/dmrb](http://www.dft.gov.uk/ha/standards/dmrb).

**1.4** Any reference to “the Regulations” or “the Directions” is a reference to the Traffic Signs Regulations and General Directions 2002 applicable to England, Scotland and Wales. Reference to a diagram number or to a Schedule is a reference to a diagram or schedule in those Regulations. In Northern Ireland the relevant legislation is the Traffic Signs Regulations (Northern Ireland) 1997. Diagram and regulation numbering occasionally differs in the Northern Ireland Regulations; this is noted in the text where appropriate. Not all signs referred to in the text are included in the latter Regulations. References to directions are not applicable in Northern Ireland; where these are mentioned, advice should be sought from the Department for Regional Development’s Roads Service Headquarters.

**1.5** All traffic signs (including road markings) placed on a highway or road to which the public has access must be either prescribed by Regulations or authorised by the Secretary of State for Transport,

the Department for Regional Development (Northern Ireland), the Scottish Government or the Welsh Government as appropriate. Care should be taken to ensure that no non-prescribed sign is used unless it has been authorised in writing. Failure to do so may leave an authority open to litigation. Except in the case of certain signs to indicate temporary obstructions or placed by the police in an emergency, signs may be placed only by or with the permission of the traffic authority.

## USE OF WARNING SIGNS

**1.6** Warning signs are used to alert drivers to potential danger ahead. They indicate a need for special caution by road users and may require a reduction in speed or some other manoeuvre.

**1.7** Appropriate warning signs can greatly assist road safety. To be most effective, however, they should be used sparingly. Their frequent use to warn of conditions which are readily apparent tends to bring them into disrepute and detracts from their effectiveness. Unjustified signing should not be used at individual locations simply in response to complaints from the public. Care should be taken to ensure that a route is treated consistently, especially where it crosses the boundary between two traffic authorities.

**1.8** Precise dimensions for all diagrams are indicated in the “P” series of working drawings available at [www.gov.uk/working-drawings-for-traffic-signs](http://www.gov.uk/working-drawings-for-traffic-signs). These also illustrate the permitted variants of symbols and show the correct layout of supplementary plates not illustrated in the Regulations. The “S” series of working drawings provides details of the more complex symbols and pictograms.

**1.9** Certain warning signs may be incorporated into directional signs; for further details see Chapter 7.

**1.10** Detailed guidance on the use of warning signs at road works is given in Chapter 8.

**1.11** To prevent the proliferation of obsolete signs, and unnecessary visual intrusion, direction 37 limits to a maximum of three months the period for which the signs to diagram 790 “NEW LEVEL CROSSING CONTROL AHEAD” and diagram 7014 “NEW ROUNDABOUT AHEAD”, and their variants, may be displayed. See also para 1.43 and section 7.

## VEHICLE-ACTIVATED SIGNS

**1.12** Regulation 58(7) permits certain warning signs (diagrams 504.1, 505.1, 506.1, 507.1, 510, 512, 512.1, 512.2 and 513) when displayed by means of light-emitting characters or symbols also to display below the sign, and at the same time, the legend "SLOW DOWN" in characters not less than one quarter of the height of the triangle. The signs will be triggered by vehicles exceeding a pre-determined safe speed on the approach to a junction or bend. They should be used only to supplement fixed signing, and not as a substitute for it. Vehicle-activated signs should not be considered until the fixed signing and road markings have been checked to ensure that they comply fully with the guidance in this chapter and in Chapter 5 in terms of correct size, siting, visibility and condition.

## SIGN SIZES

**1.13** Warning signs are normally prescribed in five sizes. The normal minimum size is indicated in the diagrams, with alternative sizes in brackets. All sizes are in millimetres unless stated otherwise. Signs need to be of a size appropriate to the prevailing traffic speed on the road on which they are used. On roads with a 30 mph speed limit, the smallest prescribed size of warning triangle (normally 600 mm) is usually adequate. On roads where speeds are higher, signs need to be larger. This enables them to be detected at a greater distance and ensures that drivers have sufficient time to recognise and assimilate the warning and take any necessary action before the hazard is met. The largest signs are for use on motorways or high-speed roads. Warning signs which are not appropriate for such roads are not generally prescribed in the largest (1500 mm) size. Appendix A details the appropriate size of sign for various speed ranges, based on the 85th percentile approach speed.

**1.14** Where special amenity considerations apply, or there are physical constraints on the width of sign that can be accommodated, the next smaller size can be substituted. It should however be borne in mind that smaller signs are likely to be seen later, and do not become legible until drivers are closer to them, giving less time to react.

**1.15** If the accident record suggests that drivers are failing to notice the warning, or seeing it too late to take the necessary action, the next larger size can be used. Conspicuity can also be increased by the use of yellow backing boards (see paras 1.32 to 1.34).

**1.16** Many warning signs are accompanied by supplementary plates. Appendix B recommends appropriate x-heights to match the size of the plates to the size of the triangle they are used with, and to ensure adequate legibility. There are restrictions on which plates may be used with individual signs; the plates prescribed for use with each sign are indicated below each diagram illustrated in this chapter. Detailed drawings showing the correct layouts for all permitted variants have been produced by the Department for Transport (see para 1.8).

**1.17** A special sign (diagram 7014) is prescribed to warn drivers of a permanent change in the road layout ahead (see also para 1.11). Several variants are prescribed, e.g. "GAP CLOSED AHEAD", "NEW TRAFFIC SIGNALS AHEAD" and "NEW ZEBRA CROSSING AHEAD". The x-height of the sign may vary between 50 and 200 mm (i.e. the capital letter height varies between 70 and 280 mm). The appropriate x-height at a specific site will depend upon the speed of traffic, with the 50 mm x-height suitable for speeds up to 30 mph and 150 or 200 mm for 70 mph. Intermediate sizes should be used for speeds between these extremes.

**1.18** The Traffic Signs (Amendment) (No.2) Regulations and General Directions 2011 prescribe a new sign (diagram 7014.1) to be used in the event of either a temporary or permanent reduction in headroom at a bridge. This sign previously required authorisation. The x-height may be between 50 mm and 200 mm, with the same selection criteria as for diagram 7014 (see para 1.17).

**1.19** The minimum x-height of the "ANIMAL DISEASE" sign, diagram 574, is determined in a similar manner to diagram 7014 as described in para 1.17, except that the minimum size is 40 mm. This size may be used on narrow rural roads where speeds are low and space is restricted.

## SITING

**1.20** In general, the greater the speed of approach, the further in advance of the hazard the sign needs to be placed. This is to ensure that drivers have the necessary time to respond to the warning. Appendix A sets out recommendations for the distance from the hazard at which a sign should be sited. If it is impracticable to place a sign within about 10% of the recommended distance, it should be sited further upstream of the hazard at the

nearest practicable point. It may be appropriate to supplement it with a distance plate to diagram 572 (see section 18). A sign should not normally be sited more than 10% closer than the recommended distance, as this would be unlikely to provide sufficient warning. Where this is unavoidable, a distance plate should always be used, indicating the distance to the hazard to the nearest 10 yards.

**1.21** Warning signs should normally be placed on the left hand side of the road, unless stated otherwise in the text (e.g. hazard markers to diagrams 560 and 561). However, site conditions sometimes make this impracticable. A warning sign might be placed on the right hand side on a left hand bend if it would otherwise be hidden from view, or if there would be no room for it on the left. If a sign is placed on the right hand side of the road, care must be taken to ensure that a driver would not be misled at night or in fog as to which side to pass. It will sometimes be appropriate to duplicate warning signs by providing them on each side of the road, as is recommended at the end of a dual carriageway, or on the approach to a roundabout on a high-speed road.

**1.22** It is essential that drivers have an unobstructed view of traffic signs. The distance which should be kept clear of obstructions to the sight line, whether caused by foliage, other signs or street furniture is known as the clear visibility distance. The higher the prevailing traffic speeds, the greater this distance needs to be. It is important therefore that sight lines are properly maintained so that the intended warning is not compromised. Care in siting can minimise future problems of obscuration. Sight lines should not cross private land as it will be difficult to control the growth of vegetation or the placement of other obstructions. It is equally important that warning signs should not be placed where they will obstruct the view of other signs. e.g. advance direction signs. Such problems might be avoided by siting the sign further from the hazard, or on the right hand side of the road.

**1.23** Appendix A specifies minimum clear visibility distances. These should normally be measured from the centre of the most disadvantaged driving lane. It is important that the full recommended sight line to the whole of the sign face is preserved. Trimming of foliage only in the immediate vicinity of the sign may not be sufficient; sign visibility should always be checked from the appropriate viewing distance.

## MOUNTING

**1.24** The normal mounting height measured to the lower edge of a warning sign is between 900 mm and 1500 mm above the carriageway alongside. The greater height should be used where road spray is likely to soil the sign. Where signs are erected above footways, or in areas likely or intended to be used by pedestrians (e.g. pedestrian refuges), a minimum headroom of 2300 mm is recommended, with 2100 mm as an absolute minimum. A clearance of 2300 mm should be maintained over a cycle track or shared cycleway/footway. When supplementary plates are used, the height should be measured to the bottom of the plate.

**1.25** Plates should be separated from the sign or another plate by a vertical space not exceeding the x-height of the lettering.

**1.26** Except where they support a luminaire, posts should never project above the top of the sign. This practice is unsightly, and needlessly increases visual intrusion and clutter.

## MOUNTING MORE THAN ONE SIGN ON A POST

**1.27** Research has shown that the greater the number of signs which drivers are presented with simultaneously, the greater the difficulty they are likely to have in assimilating the information. This problem in dealing with information overload increases with age, so that older drivers suffer disproportionately. Generally, therefore, not more than two signs should be mounted on one post. When a sign is accompanied by a supplementary plate, the combination of sign and plate should be regarded as one sign for this purpose. Exceptionally, three signs may be mounted on one post provided none requires a supplementary plate.

**1.28** Warning signs should not be mounted on the same post as a STOP or GIVE WAY or terminal speed limit sign, nor mounted on a traffic signal post. When mounted with other types of sign, the triangular warning signs should always be mounted at the top.

**1.29** Where two or more warning signs are erected together, the sign relating to the hazard first encountered should be placed uppermost. When a new sign is added to an existing post, it is important to ensure that the correct order is maintained, if necessary adjusting the position of the existing signs.

**1.30** Generally no assembly should exceed a height of 4 m above ground level. All proposed assemblies should be critically examined to ensure that the intended warnings are clear. Account should always be taken of the potential environmental impact of tall and cluttered arrays of signs.

**1.31** It should also be borne in mind that high-mounted signs may receive little light from vehicle headlamps, particularly on dipped beam. Where such signs are not directly lit but rely on reflectorisation to be seen at night, they are likely to be less legible (see also para 1.36).

## BACKING BOARDS

**1.32** To improve conspicuity against a complex or dark background, a warning sign may be mounted on a grey or yellow backing board (direction 42). A backing board can also make for a neater assembly, e.g. when a sign requires a supplementary plate, and also eliminates the risk of the plate becoming misaligned. A yellow backing board must be rectangular in shape, but a grey board may be non-rectangular, e.g. to enable a triangular sign to be bracketed off a lighting column (see Chapter 1). A backing board must not itself be provided with a border, nor give the impression of being an additional border. Where it seems that a sign is not being noticed by drivers, it should be checked to ensure that it is well-sited, not obscured by foliage or other obstructions, and is of the appropriate size and in good condition. Only then should the use of a yellow backing board be considered.

**1.33** A yellow backing board may be reflectorised to increase its conspicuity at night. This should not usually be necessary on unlit roads, although it might sometimes be helpful on lit roads, particularly where the sign itself is unlit. It may also be fluorescent; this greatly increases conspicuity in dull weather and at dusk. Fluorescence can also be particularly effective in drawing attention to signs mounted in deep shadow, e.g. below overhanging trees. However, fluorescence is visually intrusive and should be used with discretion. The new true yellow materials are less garish than the original yellow-green type and are much to be preferred.

**1.34** There are potential disadvantages to the use of backing boards. The larger overall size of the assembly can sometimes obstruct sight lines. A backing board can deprive triangular signs of a

primary recognition aid; their distinctive silhouette. Yellow backing boards can be especially environmentally intrusive, and their over-use could eventually devalue their attention-attracting benefits. A less garish way of increasing a sign's conspicuity is simply to provide a standard sign of larger size. Not only will this be more noticeable than a smaller sign, but it will also improve legibility and hence reading distance, which a yellow backing board cannot. Detailed guidance on the correct design and use of backing boards can be found in Chapter 7 (paras 14.19 to 14.24).

## ILLUMINATION

**1.35** On unlit roads, reflectorisation generally produces an adequate level of sign luminance in the illumination from a vehicle's headlamps. In areas of street lighting, however, much higher levels of luminance are required to ensure that signs are always adequately conspicuous. Reflectorised materials cannot guarantee luminance levels comparable to those provided by direct lighting. Modern microprismatic materials achieve high luminances for many drivers in defined situations, but not for all drivers in all circumstances.

**1.36** Except in Northern Ireland, the current Regulations therefore require most regulatory and warning signs to be directly lit when sited within 50 metres of a street lamp which forms part of a system of street lighting. In most other circumstances, reflectorisation alone will be satisfactory. However, some signs are sited where they will not receive adequate illumination from headlamps, and it might then be prudent to provide direct lighting regardless of the regulatory requirements. Examples include signs mounted unusually high above the level of the carriageway, or on the off side of the road. Retroreflection is also less effective where the sign is presented at a large angle to the direction of oncoming traffic.

**1.37** Illumination requirements are referenced as Item 5 in the tables associated with each diagram illustrated in the Regulations, and the detailed requirements set out in Schedule 17. Most warning signs are required to be illuminated in accordance with Schedule 17 Item 1 or Item 4. Item 4 allows a simple alternative between reflectorisation and direct lighting, wherever the sign is sited. Item 1 signs are required to be directly lit if they are sited within 50 metres of a street lamp forming part of a system



of street lighting. However, certain exceptions are permitted in paragraph (4) in column (3) of Item 1. These include road works signs on a road where the permanent speed limit is 40 mph or less and signs marked with an asterisk in column (2), provided they are placed on a single carriageway road which is not a principal or trunk road and has a speed limit of 30 mph or less. Signs that qualify for this exemption from direct lighting need only be reflectorised, although they may be directly lit. It is recommended that high-performance microprismatic retroreflective materials are used where an asterisked sign is reflectorised instead of being directly lit. Materials that offer performance little better than conventional beaded sheetings are unlikely to be adequate.

**1.38** All warning signs, including those used at street works and road works must therefore be either reflectorised or directly lit, except for the overhead black and yellow hazard markings and white chord markings used on railway bridges and similar structures, where this is optional. It is recommended that signs that are directly lit are also reflectorised in order to maintain some degree of illumination in the event of failure of the lighting. Where a sign is reflectorised, all parts of the sign face not coloured black must be reflectorised (regulation 19). Partial reflectorisation is unlawful, as is partial lighting.

## MAINTENANCE

**1.39** Over a period of years, signs gradually become faded and their retroreflective properties diminish. This will reduce both conspicuity and legibility, by day and by night. Excessively discoloured or faded signs (e.g. white backgrounds which have become grey or brown, or red borders faded to pink) and signs where the legend or graphic is peeling cannot be fully effective and need to be replaced. Guidance can be found in TD 25, in Volume 8 of the Design Manual for Roads and Bridges (see para 1.3).

**1.40** Signs should be cleaned at intervals appropriate to the site conditions. Signs located where they are subject to heavy soiling from passing traffic, or algae growth (a common problem with signs beneath tree canopies) will need more frequent cleaning. Neglect reduces the external contrast between the sign and its surroundings, making it less likely to be noticed by drivers. It also reduces the internal contrast between legend and sign background, making the sign more difficult to read. Moreover, it seriously reduces light transmission through the retroreflective medium.

Dirty signs will be far less effective at night. Older drivers are particularly disadvantaged; the ageing process of the eye means that progressively more light is required to maintain the same legibility performance. Dimmer signs take longer to recognise and to read, reducing the time available for drivers to take appropriate action.

**1.41** The importance of maintaining the necessary clear visibility distance is emphasised in paras 1.22 and 1.23. Regular inspection, particularly in summer when the rapid growth of foliage and other vegetation is most likely to cause obscuration, will ensure early detection of any problems.

**1.42** A reference number may be placed on the back of a sign in a contrasting colour in characters not exceeding 50 mm in height (direction 42(3)). It is unlawful, as well as distracting and unsightly, to place reference numbers on the sign face or on the front of a backing board.

## TEMPORARY SIGNS

**1.43** Certain signs are intended to be displayed only during transient conditions. These include diagrams 551.1 (Migratory toad crossing), 554 (Flood or No smoking), 554.2 (Ice), 556 (Uneven road), 557 (Slippery road) and some applications of 562 plated with 563 (Other danger). They should be removed when the danger has passed. Many temporary signs are specifically required by the Directions to be removed when the problem they warn of no longer applies, including diagram 574 "ANIMAL DISEASE" and variants of diagram 7010.1 "ROAD AHEAD CLOSED" etc. Diagram 7014 warns of a permanent change in road layout or new traffic signals etc; this sign must be removed within three months of completion of the works (direction 37). Diagram 7014.1 warns of a reduction in headroom at a bridge. Where this reduction is temporary, the sign may be retained only for the duration of the reduction. When a permanent reduction occurs, resulting in headroom of less than 16'-6" (5.03 m), the sign may be retained for a period of six months (see para 7.9). Authorities that fail to comply with their statutory responsibilities to remove redundant signs not only devalue the signs but contribute to sign clutter.

**1.44** Regulation 53(1)(e) permits a traffic authority to provide a temporary sign to warn of a temporary hazard caused by works being executed on a road,

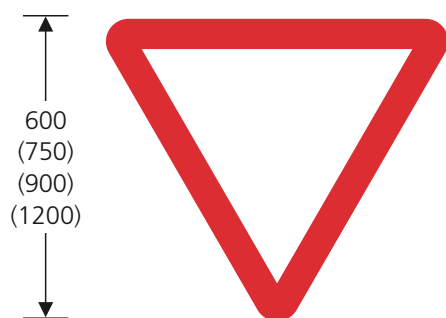
adverse weather conditions or other natural causes, the failure of street lighting or malfunction of or damage to other equipment used in connection with the road, or damage to the road itself. Direction 38 requires such signs to be removed as soon as the hazard has passed, and in any case within six months.

**1.45** A sign prescribed in the Regulations must be used where the warning can be conveyed by such a sign. Otherwise it may be designed following the requirements specified in regulation 53. The back of a temporary sign must be grey, black or in a non-reflective metallic finish, as for almost all other signs (direction 42). The use of a yellow or other coloured back is unsightly, visually intrusive and unlawful.

## 2 JUNCTIONS

2.1 The sign to diagram 501, together with a plate to diagram 502 or 503 showing the appropriate distance, should be used where the clear visibility distance (see paras 1.22 and 1.23) to the STOP or GIVE WAY sign is less than the distance given in table 2-1. The sign may also be accompanied by the word SLOW (diagram 1024) marked on the carriageway. Where the junction is with a dual carriageway road, a plate to diagram 608 may be added below the STOP or GIVE WAY plate (see also paras 5.15 to 5.17). Where there is a gap in the central reservation and a right turn is permitted, this should reduce the

risk of drivers turning into the wrong carriageway. See Chapter 3 for further guidance on the STOP and GIVE WAY signs, and Chapter 5 for road markings at junctions.



501 Junction ahead controlled by a STOP or GIVE WAY sign



502 Distance to a STOP line



503 Distance to a GIVE WAY line



608 Dual carriageway

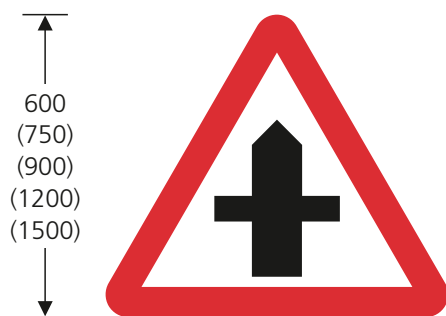
Diagram 501 may be used only in combination with a supplementary plate to diagram 502 or 503. The supplementary plates may not be used alone. The distance may be varied (see Appendix C). A supplementary plate to diagram 608 (Dual carriageway) may be used in addition to a plate to diagram 502 or 503

Table 2-1 Advance warning sign criteria, sizes and siting

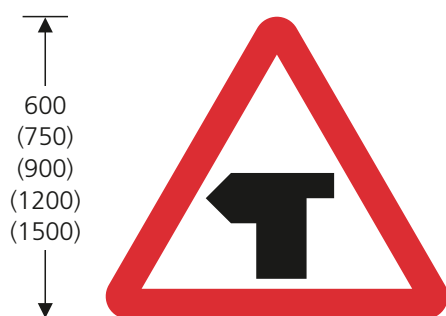
| 85th percentile speed<br>(mph) | Clear visibility distance below which an advance warning sign should be provided<br>(m) | Size of advance warning sign (see note 1)<br>(mm) | Supplementary plate x-height (see note 1)<br>(mm) | Distance of advance warning sign from STOP or GIVE WAY line (see notes 2 and 3)<br>(m) |
|--------------------------------|---|---|---|--|
| Up to 30                       | 45  | 600   | 62.5  | 45   |
| 31 to 40                       | 60  | 750 (600)   | 75 (62.5)   | 45-110   |
| 41 to 50                       | 90 (150)  | 900 (750)   | 100 (75)  | 110-180  |
| Over 50                        | 150   | 1200 (900)  | 125 (100)   | 180-245  |

### NOTES

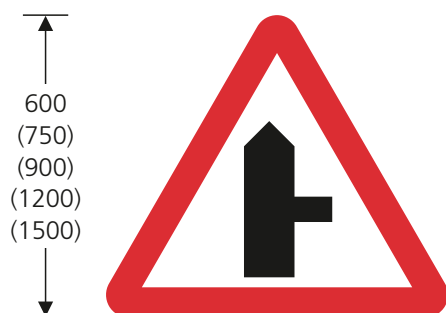
- Alternative sign sizes are shown in brackets. As these are safety-critical signs warning of a requirement to give way or stop, the smaller alternative should be used only where physical constraints make this necessary or, exceptionally, where special amenity considerations apply. A larger size than recommended may be used where the accident record justifies greater emphasis, as may the greater clear visibility distance in column 2. The size of the supplementary plate is matched to the corresponding sign, e.g. 62.5 mm with 600 mm, 100 mm with 900 mm. The 50 mm size plate to diagram 608 is not used with this sign.
- Reference should be made to Note 5 in Appendix A for more specific guidance on siting distance.
- The distance shown on the supplementary plate must always be in yards, to the nearest 10 yards. Metres must not be used.



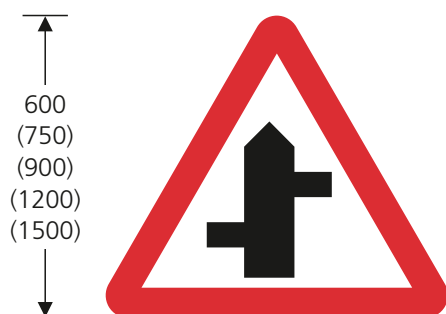
504.1 Crossroads ahead



505.1 T-junction ahead



506.1 Side road ahead



507.1 Staggered junction ahead

These signs may be used with diagram 511 or 572. Diagram 506.1 may additionally be used with 7301 "WORKS ACCESS" or 7302 "WORKS EXIT". For permitted variants see para 2.3

## PRIORITY JUNCTIONS

2.2 Signs to diagrams 504.1 to 507.1 indicate the presence of a junction. The priority route is indicated by the thicker route symbol. This may not necessarily be a route of the same status or with the same route number. The signs may be used only on the priority route, i.e. the width of the part of the symbol indicating the approach arm must not be varied. Diagram 505.1 must not be used on an approach that does not have priority at the junction. Where advance warning of the junction is considered necessary on the non-priority approach, diagram 501 with the appropriate distance plate should be used.

2.3 Diagrams 505.1, 506.1 and 507.1 may be reversed. Diagrams 504.1, 506.1 and 507.1 may be varied so that the thicker symbol indicates the priority route, except that in diagrams 504.1 and 507.1 the thicker symbol must not indicate that a priority route is crossing ahead; the STOP or GIVE WAY sign to diagram 601.1 or 602 should be used in these circumstances. Details of the variants are shown on the working drawings (see para 1.8). No other modifications are permitted.

2.4 The sign to diagram 507.1 should be used only in the following circumstances:

- (i) where the 85th percentile speed of traffic is 30 mph or less and the stagger does not exceed 50 m, or
- (ii) where the 85th percentile speed of traffic is greater than 30 mph and the stagger does not exceed 120 m.

2.5 If the priority route is itself the staggered route through the junction, diagram 507.1 must not be used, but a map-type advance direction sign might be beneficial. In all other cases, the two junctions should be signed individually with signs to diagram 506.1. A supplementary distance plate to diagram 572 (see section 18) should be provided at the second sign in cases where the siting distance shown in column 4 of the table in Appendix A is greater than the distance between the two junctions.

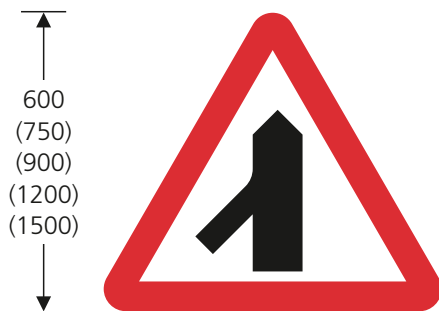
2.6 Warning signs should not generally be used where the indication of a junction is given by a map-type advance direction sign. Nor is a warning sign normally required when a stack-type advance direction sign is used, except where the layout will not otherwise be apparent, e.g. at a staggered

crossroads. Signs are required at junctions controlled by traffic signals only in the circumstances described in para 8.3. Exceptionally, warning signs may be provided in addition to advance direction signs where visibility is so poor that drivers are unable to obtain an adequate advance view of the junction or the directional signs associated with it.

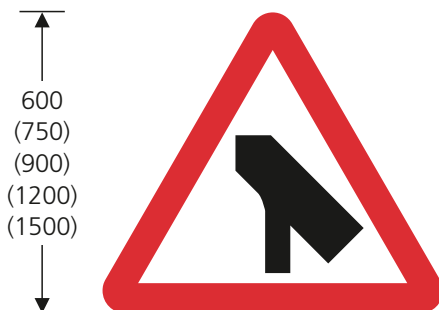
2.7 Junction warning signs are not normally provided on very minor rural roads, nor in urban areas where it would be impracticable to sign every junction. They may of course be used where a specific need has been identified.

### TRAFFIC MERGE

2.8 A sign to diagram 508.1 or 509.1 is used to give warning where two physically separated streams of traffic proceeding in the same direction join the same carriageway. These signs may be used only in situations where the traffic stream joining from a



508.1 Traffic merges ahead from the left



509.1 Traffic merges ahead onto main carriageway

*These signs may be used only in conjunction with diagram 1010 and may be used with diagram 572*

slip road crosses a road marking to diagram 1010 (direction 17) and is required to concede priority to any through traffic. They are not intended for use at lane gain junctions where one or more traffic lanes are added to the main carriageway. Diagrams 868, 868.1 and 873 to 876 may be used in these circumstances.

2.9 The sign to diagram 508.1 is used to warn that there is traffic joining on the left hand side and should be sited on the left of the main carriageway. The sign to diagram 509.1 is used to warn drivers that they are about to join a main carriageway and may have to concede priority. Neither sign is reversible. The designs prescribed in the 1964, 1975 and 1981 Regulations (diagrams 508 and 509) where both arms of the symbol have equal weight, were required by the 1994 Regulations to be removed by 31 December 1998 and are now therefore unlawful.

2.10 Traffic merge warning signs should normally be used only in the following circumstances:

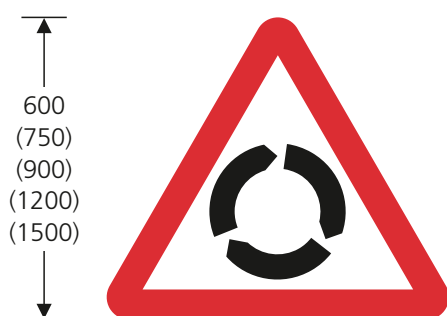
- (i) where there is no other advance signing on a main carriageway indicating a junction ahead, e.g. where there is an access slip road, but no exit slip road preceding it to alert drivers to the likelihood of joining traffic, or
- (ii) where there is a series of closely-spaced junctions which are a mixture of lane gain and lane merge (but see para 2.11), or
- (iii) where it is not apparent to drivers that they are on a slip road (e.g. a former main road through a village joining a by-pass, or the main carriageway of a motorway joining another motorway).

2.11 Rectangular merge signs based on the lane gain signs referred to in para 2.8 are available on special authorisation (see para 1.5). These may be more appropriate in the circumstance described in para 2.10(ii). Further guidance on the use of these signs will be given in Chapter 2.

2.12 A plate to diagram 572 should be used when the distance between the sign and the merge point is different from that recommended in Appendix A (but see para 1.20).

**ROUNDBABOUTS**

**2.13** The sign to diagram 510 may be used to indicate the approach to a roundabout where adequate warning is not conveyed by a map-type advance direction sign. It may be used with a supplementary plate to diagram 511, 513.1 or 572. The roundabout warning sign should be used only for true roundabouts. It should not be used to give advance warning of a gyratory system or where the approach to an otherwise standard roundabout is controlled by signals (see paras 8.4 and 8.5).



**510 Roundabout ahead**

*May be used with diagram 511, 513.1 or 572*



62.5  
(75)  
(100)  
(125)  
(150)  
(200)

**511 Reduce speed now**

*May be used only in combination with diagram 504.1, 505.1, 506.1, 507.1, 510, 512, 512.1, 512.2, 513, 516, 517, 520, 523.1, 524.1, 528 or 556*



50 min  
200 max

**7014 New roundabout ahead**

*A distance in yards to the nearest 10 yards may be added before, or substituted for the word "AHEAD"*

**2.14** On high standard all-purpose dual carriageway roads subject to a speed limit of 70 mph, diagram 510 should be used in addition to the map-type advance direction sign and be supplemented by a plate to diagram 511 "REDUCE SPEED NOW". One sign and plate should be situated on the central reservation 500 m in advance of the roundabout, with a duplicate on the left side 450 m in advance (see also paras 5.7 and 5.13).

**2.15** Where a roundabout on such a road follows a series of grade separated junctions, the signing described in para 2.14 should be supplemented by an additional sign to diagram 510 on each side of the carriageway, plated with diagram 572 "½ mile". On other roads, where accidents result from excessive approach speeds, signs to diagram 510 should be sited in accordance with the recommendations in Appendix A.

**2.16** At mini-roundabouts, a roundabout warning sign should be provided if the clear visibility distance (see para 1.23) of the sign to diagram 611.1 is less than indicated in the relevant sections of table 2-1 and the junction is not preceded by an advance direction sign to diagrams 2024, 2119 or 2120 depicting the roundabout.

**2.17** The "REDUCE SPEED NOW" plate may be used with the diagrams detailed, where it is considered that a warning sign alone might not result in a sufficient reduction of speed to enable the hazard to be negotiated in safety.

**2.18** Where further emphasis is needed on high-speed approaches on dual carriageway roads, the countdown markers to diagrams 823, 824 and 825 may be used, sited 300, 200 and 100 yards respectively from the give way line. The background colour must be changed to green when used on a primary route, and white (with black symbols and border) on a non-primary route. The signs should normally be mounted in pairs on each side of the carriageway, with the signs on the central reservation being reversed so that the bars incline downwards to the left.

**2.19** The sign to diagram 7014 with the legend "NEW ROUNDABOUT AHEAD" (see para 1.17 for guidance on size) may be erected to warn of a new roundabout. Its use is restricted to a period of not more than 3 months from completion of the works (direction 37), after which it must be removed.

## 3 DEVIATION OF ROUTE

### BEND SIGNS

3.1 Diagram 512 should be used to give advance warning of a bend which a driver might find difficult to negotiate without slowing down and the severity of which cannot easily be seen either by day or by night. The symbol should indicate a bend to the left or right as appropriate. The degree of danger at a bend varies mainly with four factors - the speed of approach, the radius of curvature, the superelevation and the skid resistance of the road surface. No uniform objective test can be applied and traffic authorities must rely on a subjective assessment of these factors when deciding whether to use the sign.

3.2 The radius of curvature not only affects the safe speed appropriate to the bend, it might also reduce forward visibility so that drivers need to slow down.

3.3 The sign should be used sparingly and only to indicate a bend hazard. It should not be used simply to allay local apprehension regarding the speed of traffic. Over-use of the sign could eventually compromise its contribution to road safety.

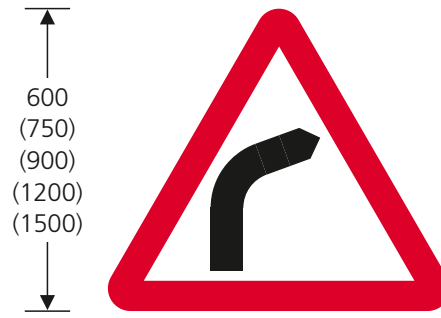
3.4 On high standard all-purpose dual carriageway roads, the signs should be erected in advance of any bend of radius less than 450 metres.

3.5 Edge of carriageway markings may be used with this sign. It might also be appropriate to change the centre line to a warning line. Chapter 5 gives further guidance on the use of these markings.

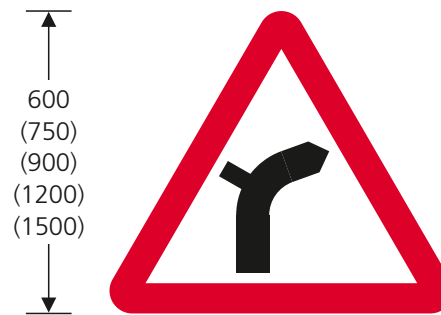
3.6 Where junctions which warrant signing in accordance with para 2.2 occur on sharp bends, use of diagrams 512.1 or 512.2 avoids the need for separate signs.

3.7 The sign to diagram 513 should be used only where bends of similar severity follow in close proximity. The symbol must be reversed where the first bend is to the right; drivers are likely to be misled if it is in the opposite direction to that indicated. The sign should be used only when the distance between the bends is less than that given in table 3-1. See Appendix A for further guidance on the size and siting of warning signs.

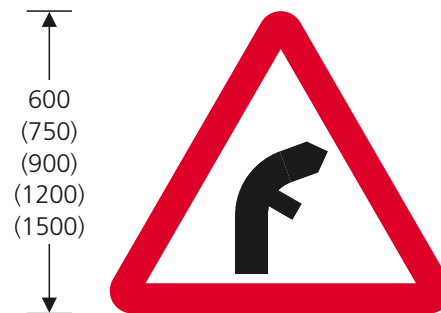
3.8 The distance plate (diagram 570, see section 18) should be used where a series of bends follow each other at distance intervals less than those referred to in the table. Where a double bend sign is used with a distance plate, bends or combinations of bends



512 Bend ahead



512.1 Junction on a bend ahead



512.2 Junction on a bend ahead

*These signs may be used with diagram 511, 513.1, 513.2, 526 or 575. The symbols may be reversed*



513 Double bend ahead

*May be used with diagram 511, 513.1, 513.2, 526, 570 or 575. The symbol may be reversed*



Table 3-1

| 85th percentile speed (mph) | Sign size (mm) | Distance between bends (m) |
|-----------------------------|----------------|----------------------------|
| Up to 30                    | 600            | 100                        |
| 31 to 40                    | 750            | 200                        |
| 41 to 50                    | 900            | 250                        |
| 51 to 60                    | 1200           | 300                        |
| Over 60                     | 1500           | 350                        |

NOTE: The distance between bends is measured from the end of one bend to the start of the next.



513.1 Adverse camber

May be used only in combination with diagram 510, 512, 512.1, 512.2 or 513

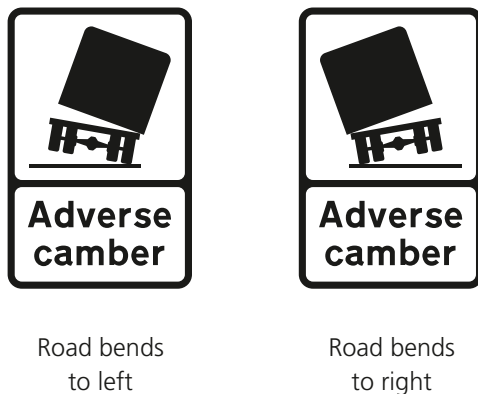


Figure 3-1 Risk of lorries overturning on adverse camber

This sign requires authorisation



513.2 Maximum speed advised

May be used only in combination with diagram 512, 512.1, 512.2, 513 or 7009. The speed may be varied

occurring within the distance shown on the plate should not be signed individually. However, they may be highlighted individually using diagram 515 (see paras 3.13 to 3.19).

**ADVERSE CAMBER**

3.9 Use of the adverse camber plate to diagram 513.1 to supplement a bend warning sign may be appropriate for signing a sharp bend where no superelevation has been applied. The sign may be used in other circumstances where loss of control accidents are attributed to insufficient superelevation, e.g. a right hand bend on a steep downhill gradient, or when circulating a roundabout. However, over-use will devalue the sign and it should be used only where the problem is likely to be severe.

3.10 Drivers should expect to encounter adverse or insufficient camber on roundabouts. While approach alignment should ideally ensure that vehicles, particularly HGVs, enter the roundabout at a safe speed, this is not always possible. Where there is a problem of large vehicles overturning on the entry to, or circulatory carriageway of, a roundabout, the non-prescribed sign to diagram NP 423 (see figure 3-1) can be considered. The lower panel can be omitted or varied to diagram 513.2. Note that this sign requires special authorisation (see para 1.5). Although this sign includes a pictorial representation of an overturning lorry, it lacks the recognisable red triangle. It should therefore be used only to supplement standard warning signs.

**MAXIMUM SPEED ADVISED**

3.11 The advisory speed sign to diagram 513.2 "Maximum speed advised" is prescribed for use only in combination with the "Loose chippings" sign to diagram 7009 (see para 12.4) or the bend warning signs to diagrams 512, 512.1, 512.2 or 513. The sign should be used sparingly, as in general it should be for drivers to judge what speed to adopt. It is not easy to determine a standard safe speed to negotiate a bend; factors which influence this include radius of curvature, camber/superelevation, road surface condition and type of vehicle. The sign may be used where the road layout is such that a driver might be misled, e.g. at an exit from a high-speed road where significant slowing is required before negotiating a sharp bend. It may also be used on high-speed roads where the horizontal design radius cannot

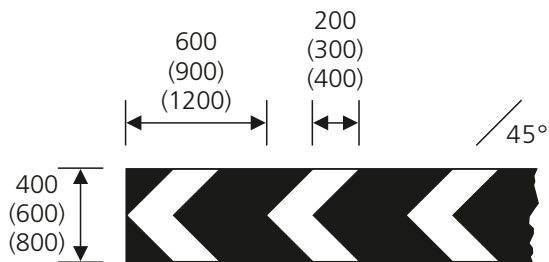


be achieved, but a mandatory speed limit is not imposed. It must not be used with mandatory speed limit signs, nor in place of repeater signs.

**3.12** An alternative to diagram 513.2, where drivers tend to enter a bend at excessive speed, is to plate the bend warning sign with diagram 511 "REDUCE SPEED NOW" (see para 2.17).

### CHEVRON SIGNS

**3.13** The sign to diagram 515 should be used on roundabouts to face traffic on each approach and elsewhere to denote sharp changes in the direction of a road where a "bend" sign alone would not be a sufficient warning. The sign may also be used at a T-junction where the major road turns through 90°. Care should be taken to ensure that a route is signed uniformly, with successive bends of similar severity always treated consistently.



**515 Sharp deviation of route**

*The number and direction of chevrons may be varied. May be used with diagram 515.2 and when used on the central island of a roundabout must be used with diagram 606*

**3.14** Because the sign is often mounted in a position where it is especially vulnerable to being struck by a vehicle of which the driver has lost control, supports that will yield easily under impact should be considered (see also para 3.22).

**3.15** Chevron signs should never be mounted one immediately above the other, as this produces a confusing zig-zag pattern. They must not be supplemented by diagonal stripes, chequering or other unlawful background markings. Where greater conspicuity is required, perhaps because of the background the sign is viewed against, a yellow backing board may be used. The width of the yellow area should not be less than half the horizontal width of the white chevron. Alternatively, a larger size sign to diagram 515 may be provided. Increasing the size

of the chevrons will result in the sign being seen earlier, provided that sufficient sight distance is available. The improved conspicuity and legibility distance might encourage a greater speed reduction.

**3.16** The sign is prescribed in heights of 400 mm, 600 mm and 800 mm. The smallest size is intended to be used where the 85th percentile speed on the approach to the bend does not exceed 50 mph. The 600 mm size should be used for approach speeds between 51 and 60 mph, and 800 mm where speeds exceed 60 mph. To minimise the potential danger of sharp edges, the corners may be rounded, with a radius not greater than 10 mm. When sited adjacent to areas used by pedestrians, the vertical edges of the sign plates should also be protected, e.g. by the use of rectangular posts flush with the edges of the sign.

**3.17** A sign should normally comprise a minimum of two chevrons. A series of single chevrons is difficult to install and maintain in alignment and should be used only where there is inadequate space for longer assemblies. On long bends, a greater number of chevrons may be required. Single chevrons are also vulnerable to being turned. This is potentially serious as they might then give a misleading impression to a driver approaching from the opposite direction. This can be avoided by using two posts, or one square post. The shortest prescribed sign is a single module extending from the tip of one chevron to the tip of the next, as illustrated in the diagram.

**3.18** Care must be taken when positioning chevrons to ensure that they do not mislead drivers from the opposite direction. Chevrons signs should be placed so that vehicles are required to pass in front of them and not behind. They should never be used in advance of a bend as an alternative to diagram 512.

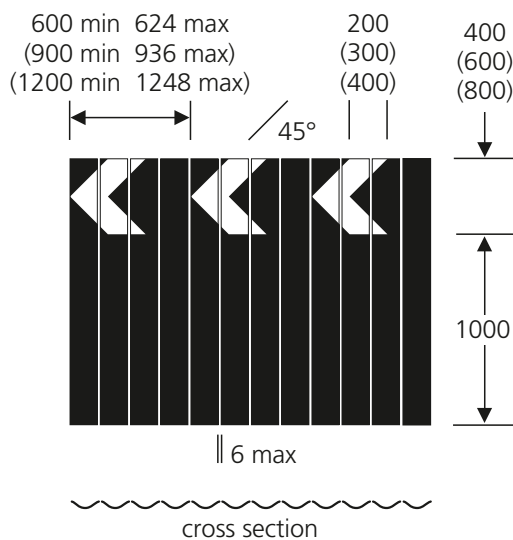
**3.19** The normal mounting height is 1000 mm to the lower edge of the sign, but greater mounting heights may be appropriate to meet particular circumstances, e.g. where a bend is partly hidden over the brow of a hill. When used on the central island of a roundabout, the height should be measured from the kerb level to the centre of the chevron, and the sign must be accompanied by the directional arrow to diagram 606 (direction 20(3)). This may be mounted above, or at the same level as the chevrons but in front of them. In the latter case, at least one complete chevron should be visible on each side.

**3.20** These signs may be used on all roundabouts other than mini-roundabouts. In practice it will not be necessary to use them at the very smallest roundabouts, provided the speed limit is 30 mph or less, the diagram 606 arrow being sufficient. They should normally be used whenever the diameter of the central island exceeds 8 metres.

**3.21** If the sign is used in the central reserve or on the off side of a slip road on the immediate approach to a roundabout, it should not be sited where it would impair the driver's view of circulating traffic.

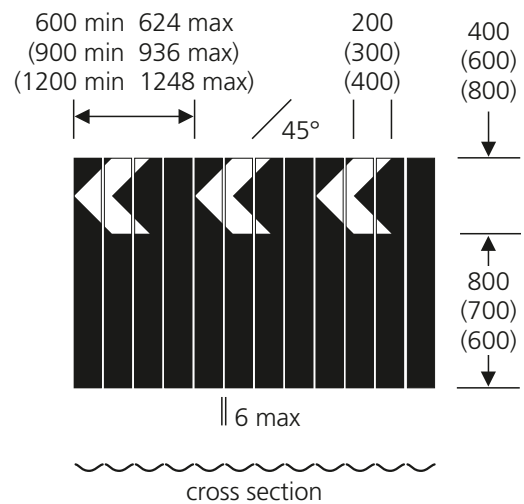
**3.22** Diagrams 515.1 and 515.1A are made from flexible material and designed to recover when struck by a vehicle. In other respects these signs are similar to diagram 515. Their use at particularly vulnerable locations might help to reduce maintenance costs.

**3.23** The sign to diagram 515.2 is formed of block paving on the perimeter of a roundabout. It must always be accompanied by a vertical sign to diagram 606 facing each approach, but the paving may be used together with or in place of diagram 515 or 515.1A. This arrangement may be used on any roundabout with a diameter of 4 metres or more. The larger width of chevron (600 mm) should be used when the space between adjacent chevrons is equal to or greater than 1200 mm. In such cases either eleven or thirteen courses should be used. The white blocks must be be reflectorised. Authorities considering such installations should take the maintenance implications of dirt and weed control into account.



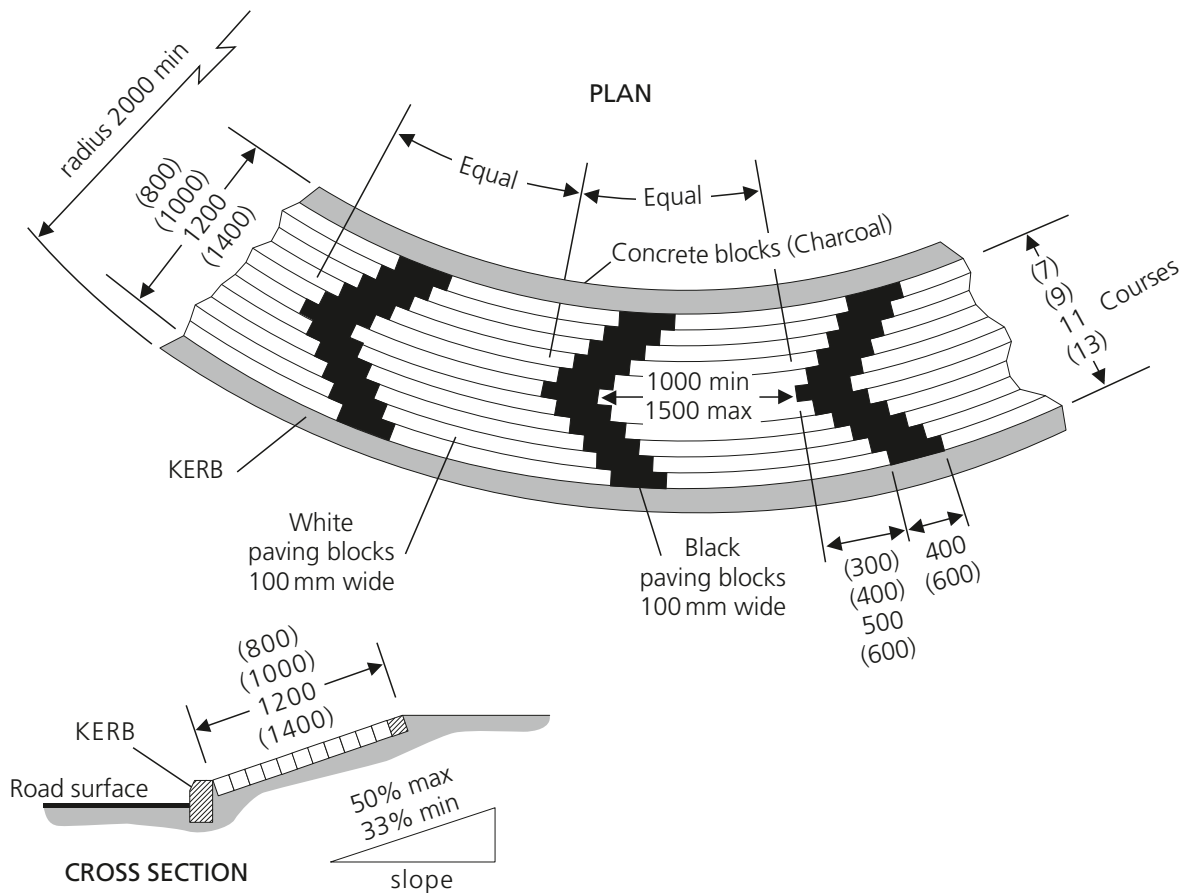
**515.1 Flexible form of diagram 515**

*The number and direction of the chevrons and the number of elements making up the sign may be varied*



**515.1A Flexible form of diagram 515 for use at roundabouts**

*May be used only in combination with diagram 606. May also be used with diagram 515.2. The number of chevrons and the number of elements may be varied*



**515.2 Similar to 515 but constructed of block paving**

*May be used only in combination with diagram 606. May also be used with diagram 515 or 515.1A*

## 4 ROAD NARROWS

4.1 Signs to diagrams 516 or 517 should be used where a reduction in width on a single carriageway road presents a hazard. Dual carriageway situations are dealt with in para 4.6. Signs will not normally be needed if the narrowing does not result in the loss of a lane and involves a taper no more severe than indicated in table 4-1. However, signs should be provided regardless of the rate of taper where a lane is lost on a single carriageway road or where the reduction in width is so great that the centre line marking has to be omitted (see also para 4.4). The "REDUCE SPEED NOW" plate (diagram 511) should be used if a significant speed reduction is advisable. These signs must not be used to warn of the termination of a dual carriageway (see diagrams 520 and 521, and paras 5.1 to 5.8).

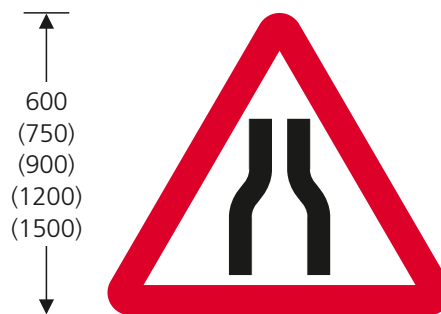
Table 4-1 Taper criteria for warning sign

| 85th percentile speed (mph) | Taper    |
|-----------------------------|----------|
| Up to 30                    | 1 in 40  |
| 31 to 40                    | 1 in 60  |
| 41 to 50                    | 1 in 80  |
| Over 50                     | 1 in 100 |

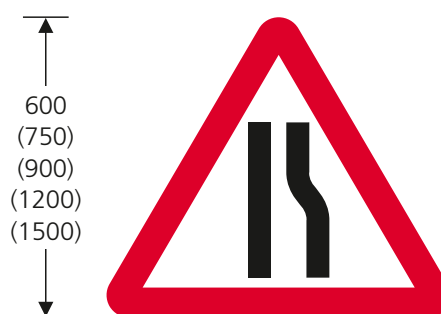
4.2 The signs may be supplemented by edge lines, hatched markings and hazard markers to diagrams 560 or 561. Diagram 575 "Oncoming vehicles in middle of road" may be used if drivers are likely to be surprised by an oncoming vehicle (see para 19.3).

4.3 The sign to diagram 517 should be used in preference to 516 if the narrowing occurs mainly on one side. Where this is the near side, the symbol is reversed. At the termination of a single carriageway climbing lane, the right hand version is used in advance of the start of the lane loss at the distance specified in Appendix A, and repeated at half this distance. The second sign is not necessary if the 85th percentile speed is below 50 mph. Details of road marking layouts and tapers for climbing lanes can be found in Chapter 5 (paras 5.27 to 5.35) and TD9 in Volume 6 of the Design Manual for Roads and Bridges (see para 1.3).

4.4 Where a road with two lanes in one direction, other than a climbing lane, narrows to a single lane, or a road with a single lane in each direction narrows to a single track, an advance warning sign with the appropriate supplementary plate to diagram 518 or 519 should always be provided. If the sign has to be



516 Road narrows on both sides ahead



517 Road narrows on right ahead

These signs may be used with diagram 511, 518, 519, 572, or 575. The symbol is reversed when the road narrows on the left



518 Single file traffic in each direction

May be used only in combination with diagram 516, 517 or 520. A distance, an arrow or both may be added



519 Road wide enough for one line of vehicles only

May be used only in combination with diagram 516 or 517. A distance, an arrow or both may be added

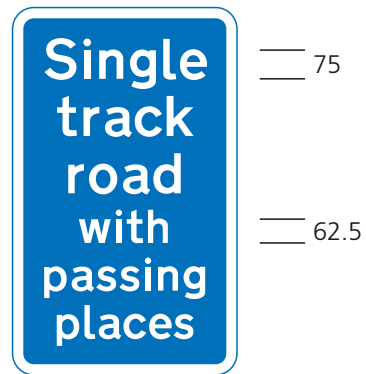
sited at a distance from the hazard significantly different from that recommended in Appendix A, a distance may be added in accordance with Schedule 16 item 6 (see Appendix C). An indication of the distance over which the restriction extends may be given, e.g. "Single file traffic for 400 yds". If the road indicated is a side road, an arrow may be added, pointing horizontally to the left or to the right. Details are shown on the working drawings (see para 1.8).

**4.5** If a road is wide enough for only one line of vehicles but there are passing places marked with diagram 822 "PASSING PLACE", diagram 821 "Single track road with passing places" should be used at each end of the single track section. The legend "with passing places" may be varied to "No passing places for" and a distance in yards or miles.

**4.6** The loss of a lane on a dual carriageway road, on a slip road at a grade separated junction or on a one-way street should be indicated using the sign to diagram 872.1. The sign illustrated is for use on a primary route. The background colour is varied to blue when the sign is used on a motorway and to white with black symbols and border when used on a non-primary route.

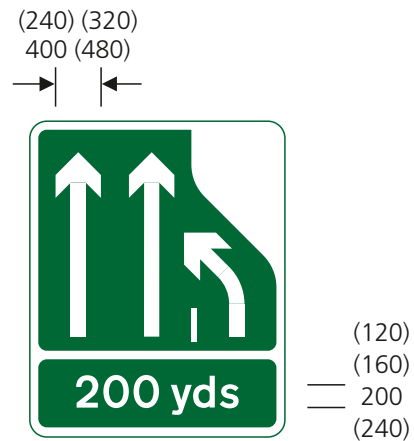
**4.7** The size of diagram 872.1 is determined by the measurement across the arrowhead. A sign is placed on each side of the carriageway, and the pair repeated on roads with higher traffic speeds. Sizes and distances from the start of the taper are detailed in table 4-2. On motorways and other dual three-lane carriageway roads subject to a 70 mph speed limit, three pairs of signs should normally be provided, at 800, 360 and 180 metres from the start of the taper.

**4.8** Guidance on the associated road markings where the number of lanes is reduced on a high-speed road can be found in Chapter 5 (para 4.53).



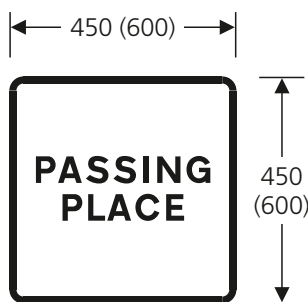
**821** Road ahead wide enough for one line of vehicles, but has passing places at intervals

*"with passing places" may be varied to "Use passing places to permit overtaking" or to "No passing places for" and a distance expressed in yards or miles as appropriate*



**872.1** Reduction in the number of traffic lanes ahead (shown with diagram 876)

*The upper panel may be reversed in a mirror image.  
The number of ahead arrows may be varied.  
The distance may be varied (see Appendix C).  
The lower panel (diagram 876) may be omitted*



**822** Passing place on a narrow road

Table 4-2 Size and siting of signs to diagram 872.1

| 85th percentile speed (mph) | Size of arrowhead (mm) | x-height of legend (mm) | First signs on approach        |         | Second signs on approach       |         |
|-----------------------------|------------------------|-------------------------|--------------------------------|---------|--------------------------------|---------|
|                             |                        |                         | Distance to start of taper (m) | Legend  | Distance to start of taper (m) | Legend  |
| Up to 30                    | 240                    | 120                     | 45 <sup>1</sup>                | None    | None                           | None    |
| 31 to 40                    | 240                    | 120                     | 135                            | 150 yds | None                           | None    |
| 41 to 50                    | 320                    | 160                     | 180                            | 200 yds | None                           | None    |
| 51 to 60                    | 320                    | 160                     | 270                            | 300 yds | 135                            | 150 yds |
| Over 60                     | 400                    | 200                     | 360                            | 400 yds | 180                            | 200 yds |
| Motorway <sup>2</sup>       | 400 (480) <sup>3</sup> | 200 (240) <sup>3</sup>  | 800                            | ½ mile  | 360 <sup>4</sup>               | 400 yds |

## NOTES

1. On two-lane carriageways subject to a 30 mph speed limit, a single sign mounted on the side of the road on which the lane is to be lost may be adequate, although the possibility of obscuration by parked vehicles should be considered.
2. Also all-purpose dual three-lane carriageway roads subject to a 70 mph speed limit.
3. Bracketed dimension is used where there are four or more lanes.
4. A third pair of signs should be provided at a distance of 180 m indicating a distance of 200 yds.

## 5 TWO-WAY TRAFFIC AND DUAL CARRIAGEWAY ROADS

### TWO-WAY TRAFFIC

5.1 The signs to diagrams 520 and 521 indicate the resumption of two-way traffic on a single carriageway road after a length of dual carriageway and, in the case of diagram 521, after a one-way road. The sign to diagram 522 indicates a two-way road crossing ahead (see para 5.4).

5.2 Pairs of opposing arrows to diagram 1038, indicating the ahead direction, may be used to supplement the sign to diagram 521. This may be particularly helpful where a single carriageway road is similar in appearance to one carriageway of a dual carriageway road.

### END OF ONE-WAY ROAD

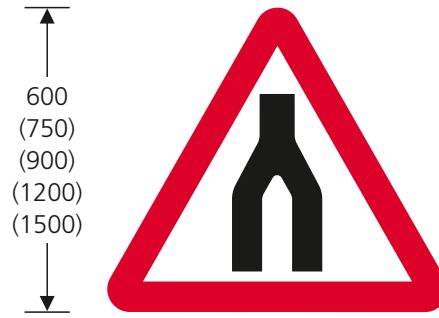
5.3 Diagram 521 should be used to indicate a change from one to two-way traffic, and also at the commencement of any two-way side roads that form a junction with a one-way road. It should be erected as close as possible to the beginning of two-way working, consistent with being readily visible to turning traffic, and may be repeated after 100 metres.

5.4 Diagram 522 is generally used on a one-way road to indicate that a road it joins or one that crosses it carries two-way traffic. It is normally sited on the back of the "no entry" sign. However, it might also be helpful on a two-way road where it is crossed by another two-way road after a succession of intersections with one-way roads.

### END OF DUAL CARRIAGEWAY

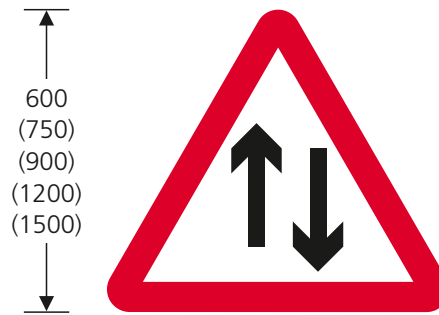
5.5 The road markings required where a dual carriageway road reduces to a single carriageway are detailed in Chapter 5. Table 5-1 below lists the appropriate tapers. Figure 5-1 illustrates the signs and markings needed in a built-up area where speeds are relatively low. The sign to diagram 520 should be sited in advance of the end of the dual carriageway at the usual distance appropriate to warning signs (see Appendix A). The sign to diagram 521 should be erected at or as near as possible to the beginning of two-way working, and may be repeated after 100 metres.

5.6 Where traffic speeds are high, as on inter-urban roads, more comprehensive signing as in figure 5-2 should be provided.



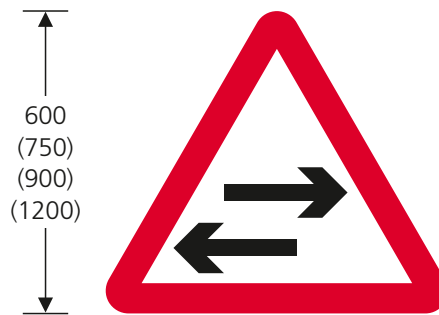
520 Dual carriageway ends ahead

*May be used with diagram 511, 518 or 572*



521 Two-way traffic

*May be used with diagram 570 or 572*



522 Two-way traffic on route crossing ahead

*May be used with diagram 572*

Table 5-1

| 85th percentile speed (mph) | Taper   |
|-----------------------------|---------|
| Up to 40                    | 1 in 40 |
| 41 to 50                    | 1 in 45 |
| 51 to 60                    | 1 in 50 |
| Over 60                     | 1 in 55 |

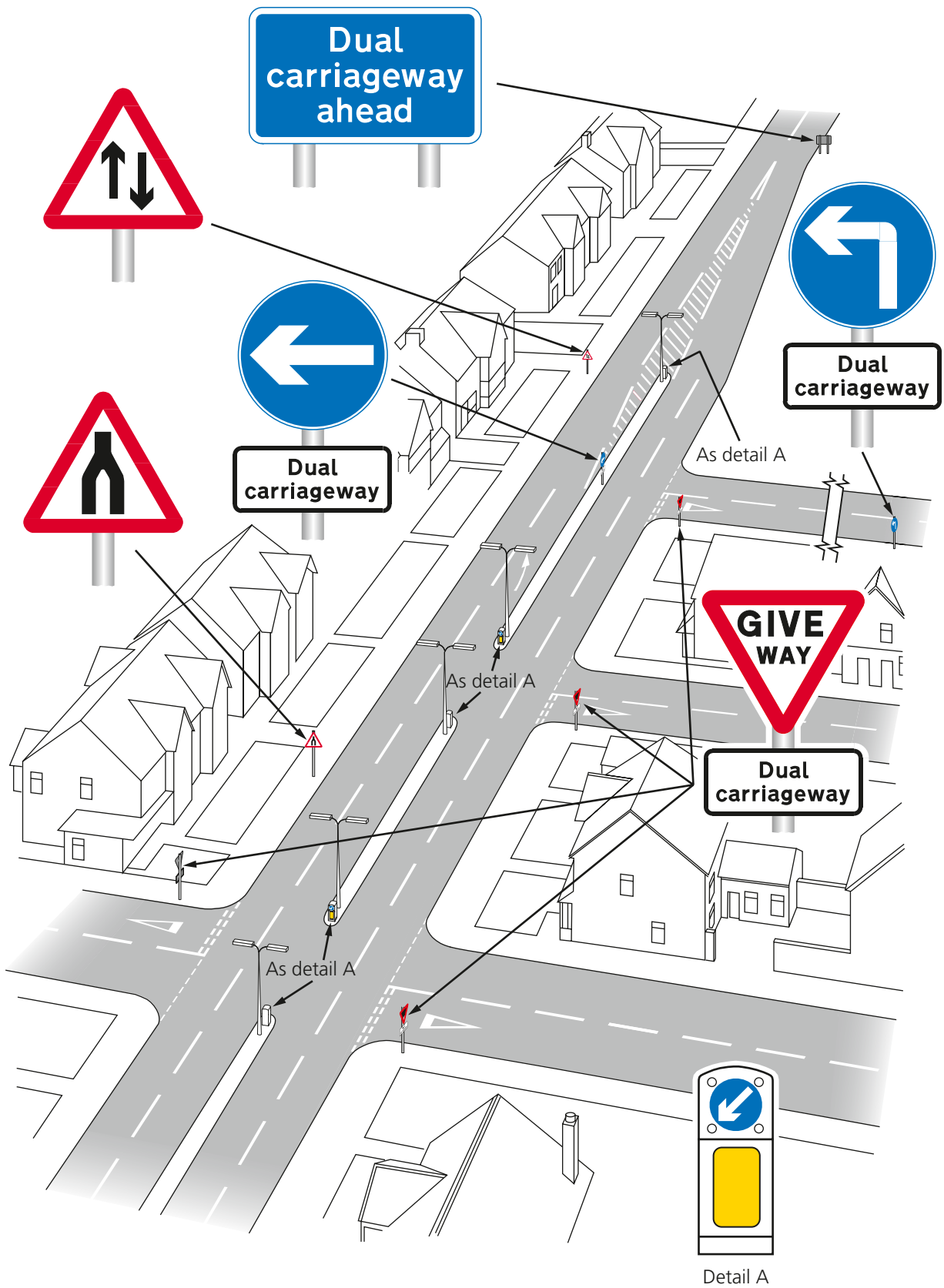


Figure 5-1  
Signing an urban dual carriageway road



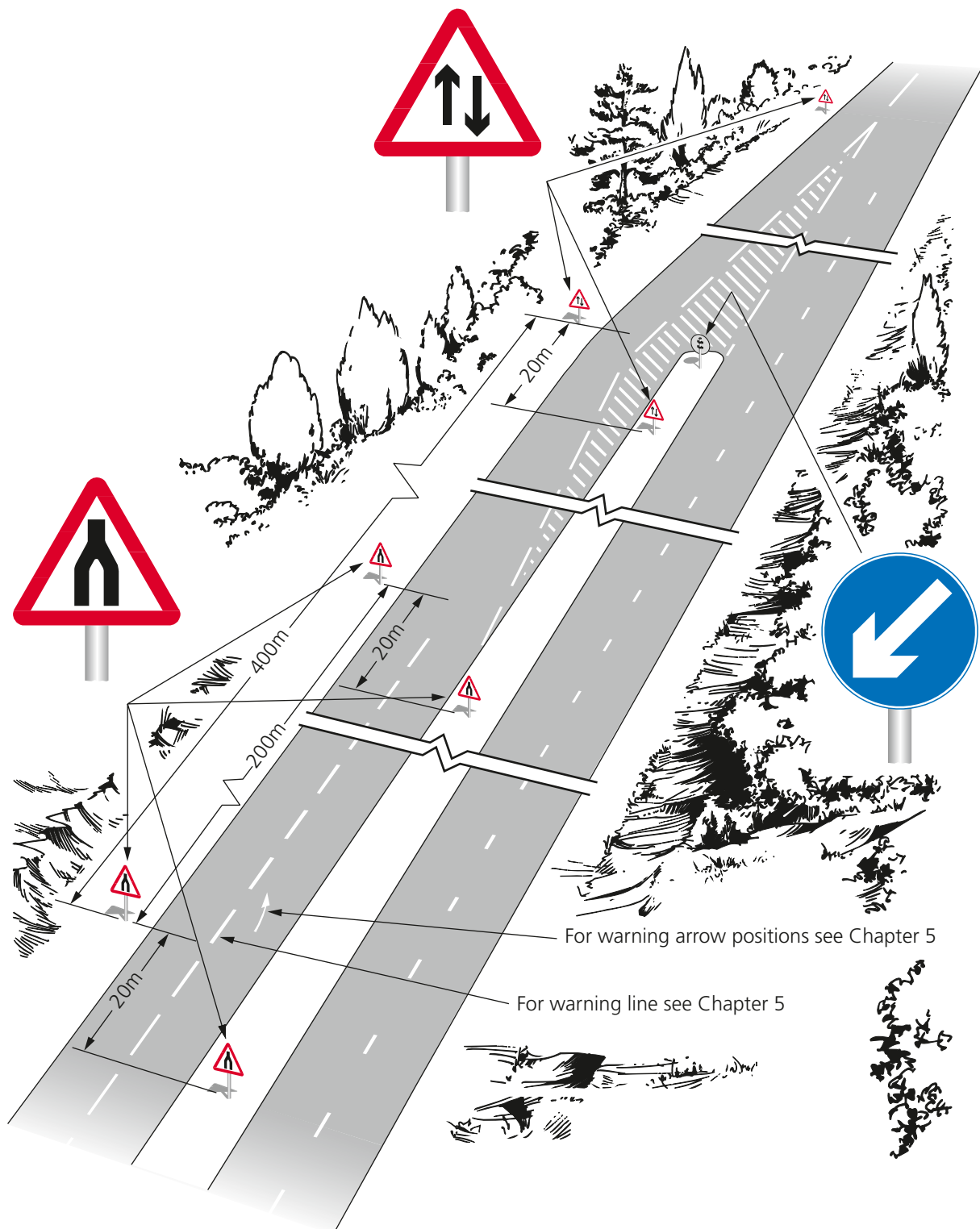


Figure 5-2  
Signing the end of a rural dual carriageway road



(75)  
100  
 (125)  
 (150)  
 (200)

818 Dual carriageway ahead



(75)  
100  
 (125)  
 (150)  
 (200)

818.1 Distance to the start of a dual carriageway

*The distance may be reduced*



(75)  
100  
 (125)  
 (150)  
 (200)

818.1A Short length of dual carriageway beginning directly ahead

*The distance "1/2" may be varied to "1/4"*

Table 5-2 Size of dual carriageway signs

| 85th percentile speed (mph) | x-height (see note) (mm) |
|-----------------------------|--------------------------|
| Up to 30                    | 75                       |
| 31 to 40                    | 100                      |
| 41 to 50                    | 125                      |
| Over 50                     | 150 (200)                |

NOTE: The larger size shown in brackets may be used on high standard single carriageway roads where speeds are high (e.g. on 10 m wide carriageways).

5.7 Where a high-speed dual carriageway road ends at a roundabout, signs to diagram 520 should be erected on both sides of the carriageway approximately 100 metres before the roundabout. A sign to diagram 521 should be erected approximately 50 metres after the roundabout. Warning signs to diagram 510 should also be used as appropriate (see paras 2.13 to 2.15).

5.8 Where speeds on the dual carriageway road are high, but the length of dualling is so short that it would not be possible to site the signs in accordance with figure 5-2, they may be sited at not less than one half the normal distance from the end of the central reservation, provided they are still duplicated on the right hand side of the carriageway.

#### START OF DUAL CARRIAGEWAY

5.9 On a single carriageway road which widens to a dual carriageway for a length of at least 400 metres, an advance sign to diagram 818 should be provided. Siting distances, normally measured back from the nose of the central hatch marking at the start of the dual carriageway, are similar to those indicated in Appendix A for warning triangles. If the dual carriageway is shorter than 400 metres, no advance sign should be provided. The sign to diagram 818.1A may be used to warn drivers that a dualled length is short and so might not be long enough to permit overtaking. The sign may display distances of "1/4 mile" or "1/2 mile" only.

5.10 Further advance warning up to a distance of two miles may also be given by a sign to diagram 818.1. This sign may be used to encourage drivers to delay overtaking until the dual carriageway is reached. Distances greater than two miles are not permitted, as this might result in impatient drivers trying to overtake on an unsuitable length of road.

5.11 For guidance on the appropriate x-height for these signs, see table 5-2.

5.12 "Keep left" signs (diagram 610) should always be placed at the start of the central reservation, and at any gaps. See Chapter 3 for further guidance.

## ROUNDBABOUTS ON DUAL CARRIAGEWAYS

**5.13** A plain bollard should be used on the central reservation of a dual carriageway or on the splitter island of any other road leaving a roundabout. A bollard may be dispensed with where a directly-lit direction sign is provided in such a position. If the physical layout does not adequately deter traffic from turning into the wrong carriageway or slip road in such situations, direction 7(3) permits “no entry” signs to diagram 616 accompanied by NO ENTRY markings on the carriageway (diagram 1046) to be used without the need for a traffic order, subject to the prior approval of the Secretary of State (see para 1.2). Further guidance on the signing of roundabouts may be found in paras 2.13 to 2.19, 3.13, 3.19 to 3.23 and 5.7.

## GAP CLOSURES

**5.14** Where a gap in the central reservation of a dual carriageway has been closed, a temporary sign to diagram 7014 (see para 1.17 for guidance on size) varied to “GAP CLOSED AHEAD” should be provided, warning drivers of the changed layout. This should be sited on the central reservation a suitable distance in advance of the closure. It will usually be helpful to add the distance in yards (to the nearest 10 yards) on a separate line after “CLOSED”. “AHEAD” may then be omitted. This sign must not be retained for longer than three months (direction 37). A “no right turn” sign (diagram 612) should be placed on the central



**7014 (variant)**  
Gap closed ahead

*A distance in yards to the nearest ten yards may be added before or substituted for “AHEAD”*

reservation immediately preceding the former gap. Although not time-limited by direction 37, this should be removed at the same time as the GAP CLOSED sign. Junction warning signs may need to be removed or replaced (e.g. diagram 506.1 indicating a side road might have to be substituted for diagram 504.1 indicating a crossroads). Amended side road signing should be in accordance with para 5.15.

## SIDE ROADS

**5.15** Where a minor road crosses or joins a dual carriageway, GIVE WAY or STOP signs (see Chapter 3) should normally be provided on the minor road, supplemented by a “Dual carriageway” plate to diagram 608 (see para 2.1). Where advance warning is needed, signs to diagram 501 supplemented by the plates 502 or 503 as appropriate should be erected in accordance with table 2-1. The “Dual carriageway” plate may be provided below these signs also.

**5.16** Special care is needed in signing minor road junctions with dual carriageway roads if the carriageways are separated by a very wide central reservation and the further carriageway could be mistaken for a separate road or cannot easily be seen by a driver on the minor road. In such cases, as an additional safeguard, NO ENTRY (diagram 1046) should be marked on the nearer carriageway to prevent drivers from turning right into it. It may also be appropriate to erect “no entry” signs (diagram 616) on each side of the nearer carriageway, angled so as to be seen by a driver attempting a right turn. Prior approval must be obtained in writing from the Secretary of State before using these signs and markings in such circumstances (see para 5.13). If the layout is not self-evident, a map-type sign on the minor road approach might be helpful.

**5.17** On a side road which joins a dual carriageway road where there is no gap in the central reservation, a “turn left ahead” sign (diagram 609) together with a “Dual carriageway” plate (diagram 608) should be used. A “turn left” sign (diagram 606) with a “Dual carriageway” plate should be erected on the central reservation opposite the side road (see figure 5-1).

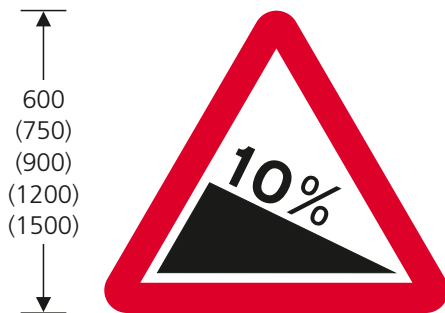
## 6 HILLS

### GENERAL

6.1 Steep hills are signed using diagrams 523.1 and 524.1 together with associated supplementary plates. The gradient is calculated using the tangent of the angle concerned, although in practice it makes little difference whether the sine or the tangent is used. The gradient on new signs must be expressed as a percentage; old signs showing a ratio may remain in place until life-expired.

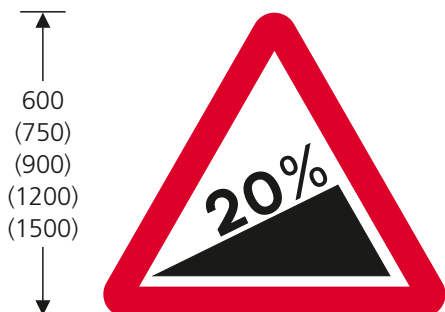
### DESCENT

6.2 The sign to diagram 523.1 should normally be used only where the gradient is 10% or more. The actual gradient to the nearest whole number should be indicated on the sign, e.g. a gradient of 10.4% should be signed as 10%, but 10.6% as 11%.



523.1 Steep hill downwards

May be used with diagram 511, 525, 526, 527, 570, 572, 573 or 817.2. The numerals may be varied (see Appendix C)



524.1 Steep hill upwards

May be used with diagram 511, 525, 526, 527, 570, 572 or 573. The numerals may be varied (see Appendix C)

6.3 On very steep or long hills where additional warning is considered necessary, the sign may be repeated as appropriate, supplemented with the "Low gear" plates shown in diagrams 525, 526 or 527. These plates must not be used alone.

6.4 The circumstances justifying the additional plates cannot be stated precisely. Traffic authorities, after consulting the police, will have to assess the need to advise drivers to engage a lower gear and gauge the likelihood of this instruction being respected. It is difficult to persuade drivers to select a lower gear to descend a long hill if their own assessment of the need is different. Where drivers have a good view of the descent and can make their own judgement, then an instruction to change gear will be obeyed only if



525 Low gear now

May be used only in combination with diagram 523.1 or 524.1



526 Keep in low gear

May be used only in combination with diagram 512, 512.1, 512.2, 513, 523.1, 524.1 or 554.1



527 Low gear for 1½ miles

May be used only in combination with diagram 523.1 or 524.1. The distance may be varied (see Appendix C)

they think it correct. Instructions should not be given if they are likely to be ignored and any existing signs which are not being respected should be removed.

**6.5** “Low gear” plates are not normally used unless the gradient overall or in part exceeds 12% and the hill is longer than 800 metres. They are more likely to be justified where there are also sharp bends.

**6.6** The instruction to “Keep in low gear” (diagram 526) should be used at intervals of not less than 800 metres where the gradient exceeds 12%; it may be accompanied by diagram 554.1 “Try your brakes” (see para 11.2). When used in advance of an escape lane, diagram 523.1 should be replaced by 554.1 as shown in table 6-1. Exceptionally, diagram 526 may be used at a shorter interval, e.g. where an increase of gradient is hidden from view.

**6.7** “Steep hill” signs without plates may be repeated on a hill where the gradient steepens but should not be placed at intervals of less than 550 metres unless the gradient increases by 5% or more.

**6.8** On long descents, certain sections may be steep whilst others are below the 10% criterion for provision of signs. It might then be better to treat the steeper parts as separate hills and sign accordingly.

**ESCAPE LANES**

**6.9** Where an escape lane or arrester bed is available, the “Escape lane ahead” sign (817.2) should be used. It should form part of a sequence of signs with “ahead” varied as in table 6-1. The sign may also be varied to show the escape lane to the left on a straight road. Permitted variants are illustrated on the working drawings (see para 1.8). The order of

**Table 6-1**

| Location                   | Warning sign | Plate | Variant of 817.2 |
|----------------------------|--------------|-------|------------------|
| At top of hill             | 523.1        | 525   | ahead            |
| 400 yards from escape lane | 554.1        | 526   | 400 yds          |
| 200 yards from escape lane | 523.1        | 526   | 200 yds          |
| At entry to escape lane    | 523.1        | 526   | arrow            |

the sign plates, from the top, should be: warning sign (523.1 or 554.1): supplementary plate (525 or 526): diagram 817.2.

**ASCENT**

**6.10** The sign shown in diagram 524.1 should be used only:

- (i) where the gradient is 15% or more, or
- (ii) where the ascent is longer than 1600 metres and the gradient is 10% or more, in which case the sign should be accompanied by a distance plate to diagram 570 (see section 18).

**6.11** The supplementary plates to diagrams 525, 526 and 527 should not normally be used with the ascent warning, except in rare circumstances e.g. where a very sharp increase in gradient is hidden from view and there is a record of accidents due to vehicles stalling and rolling back out of control.

**6.12** For signs to diagram 583 and 583.1 (indicating slow-moving vehicles) see paras 20.3 and 20.4.



50  
(62.5)  
(75)  
(100)  
(125)

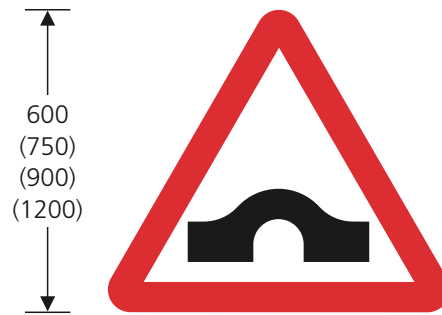
**817.2 Escape lane ahead**

*May be used only in combination with diagram 523.1 together with either 525 or 526, or diagram 554.1 with 526. The word “ahead” may be varied to a distance or to an arrow pointing to the left, or omitted. The angle of the route symbol may be varied to accord with the layout*

## 7 BRIDGES AND OTHER STRUCTURES

### HUMP BRIDGES

7.1 The sign to diagram 528 should be used where a hump bridge is so severe that unless drivers are forewarned they might lose control of their vehicles. If visibility is inadequate, double white lines or a hazard line should be laid in accordance with the normal criteria (see Chapter 5). If the hump bridge hides a further hazard, another sign indicating this should be provided on the same post (with the sign indicating the first hazard encountered placed uppermost). If there is a risk of long vehicles grounding on the bridge, diagram 782 (see para 21.13) should be used also, mounted below diagram 528. They should be sited, with a distance plate, on the approach to a junction at which vehicles can divert, and repeated at the standard siting distance from the structure (see Appendix A).

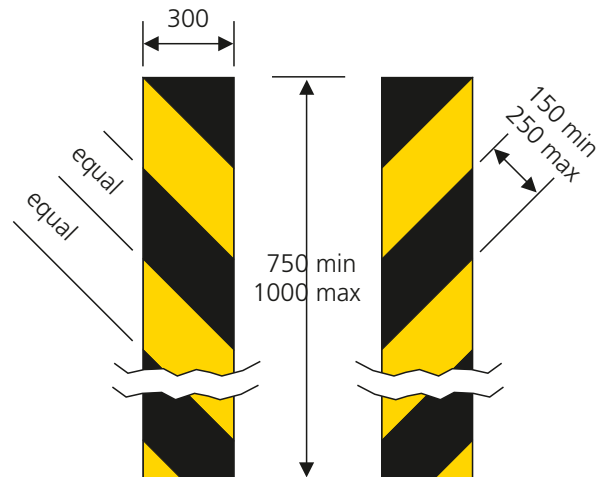


528 Hump bridge ahead

May be used with diagram 511, 572, 573, 575 or 782

### BRIDGE PARAPET OR OTHER OBSTRUCTION

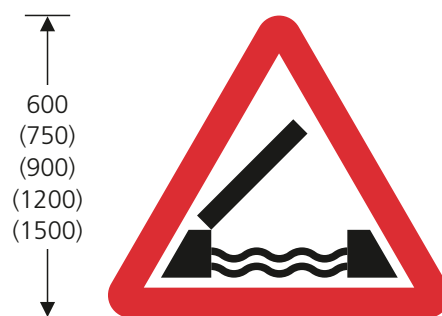
7.2 Signs to diagram 528.1 should be used where a bridge parapet, abutment or other obstruction is immediately adjacent to, or encroaches onto, the carriageway. This includes any parapet or abutment on the off side where it would be a hazard to drivers overtaking or passing a temporary obstruction on the near side. In addition to the risk to passing road traffic, damage to a parapet can also result in considerable danger to rail traffic. It is therefore particularly important that signs to diagram 528.1 on parapets or abutments of bridges are correctly installed and maintained to a high standard. The use of these signs helps to make the vulnerable parts of a structure more conspicuous. If the obstruction is accompanied by a narrowing of the carriageway, "road narrows" signs to diagram 516 or 517 (see section 4) and edge lines should also be used. The signs should be used as in the diagram, sloping downwards towards the carriageway. The Regulations permit the use of yellow material which is both retroreflective and fluorescent (see para 7.6).



528.1 End of bridge parapet or other obstruction

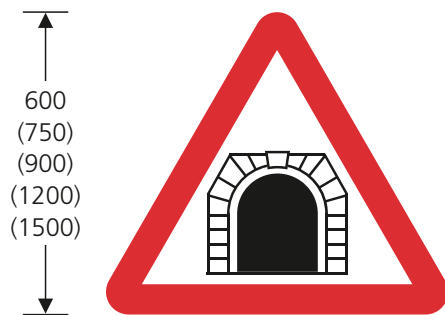
### OPENING BRIDGE

7.3 The sign to diagram 529 should be used in advance of opening bridges (lifting or swing). If movement onto a bridge is controlled by wig-wag signals to diagram 3014, a plate to diagram 773 (see section 21) should be added.



529 Opening bridge ahead

May be used with diagram 572, 573 or 773



529.1 Tunnel ahead

May be used with diagram 572, 573, 575 or 773



Figure 7-1 Name and length of tunnel on a motorway

*When indicating a tunnel on an all-purpose road, the sign has black characters on a white background with a black border. The sign is not prescribed by the Regulations and requires authorisation*

## TUNNELS

7.4 The sign shown in diagram 529.1 is for use in advance of tunnels. If the tunnel is controlled by wig-wag signals, the sign should be supplemented by a plate to diagram 773 (see section 21).

7.5 The Road Tunnel Safety Regulations 2007 require that a tunnel's length should be indicated on a sign at the portal. This should be done using a non-prescribed variant of diagram 2401 or 2928 (see figure 7-1 and para 1.5). It is not appropriate to use diagram 529.1, where the supplementary plate indicates the distance ahead to the hazard.

## LOW BRIDGES

7.6 Incidents in which road vehicles strike low bridges present a serious hazard to both rail and road users. There is a significant number of reported bridge strikes each year. It takes only a relatively small amount of force to displace bridge girders sufficiently to derail a train. Serious damage can also be caused to arch bridges. It is therefore particularly important that the signs and markings on low bridges are

correctly installed and maintained to a high standard. The use of black and yellow hazard markings helps to make the vulnerable parts of a structure more conspicuous. The yellow parts of these markings may also be reflectorised, making them much brighter at night, and fluorescent. The latter greatly increases conspicuity in dull weather and at dusk (see para 1.33 for further guidance on fluorescence). However, fluorescence is visually intrusive and is therefore best confined to structures that are known to be at risk.

7.7 The standard minimum clearance over every part of the carriageway of a public road is 16'-6" (5.03 m). Where the clearance over any part is less than this, signs should be provided. Where a dual carriageway road has hard shoulders with restricted headroom, this should be separately signed, supplemented with the hazard markings in diagram 530.2 or the chord markings used at arch bridges (see paras 7.23 and 7.24).

## MEASUREMENT OF HEIGHT

7.8 All bridges and other structures with a headroom of less than 16'-6" (5.03 m) should be clearly signed. The Regulations allow heights to be shown in either imperial units or both metric and imperial units. It is strongly recommended that both units are displayed on signs, especially on main routes and roads used frequently by foreign vehicles. Metric signs alone must not be used; either two signs or a combined metric/imperial sign must be used. Imperial and metric heights should be calculated separately.

7.9 The bridge height should be re-measured when works on the road or to the bridge might have affected the available headroom. Permanent signs should be changed if necessary and a temporary sign to diagram 7014.1 may be erected for a period of 6 months following completion of the works.



50 min  
200 max

7014.1 Reduction in bridge headroom ahead

*The height may be varied*



**7.10** Care should be taken to ensure that vehicles of the maximum length permitted by the Construction and Use Regulations will be able to pass safely under the bridge. This is particularly important where the road dips or hogs sharply or is on a curving alignment under the bridge. Changes in gradient might affect the headroom, e.g. the effective clearance will be reduced for a long wheel base vehicle spanning a dip. Where the road passing under a structure is on a sag curve, the headroom should be measured along the carriageway over a 25 m chord.

**7.11** The imperial figure shown on signs to indicate the available headroom should be at least 3 inches less than the measured height to allow a safety margin. If the resulting figure is not a multiple of 3 inches, it should be rounded down to the nearest lower multiple of 3 inches.

Example 1: measured height 15'-2", subtract 3" to create a safety margin 14'-11", round down to nearest multiple of 3" and sign as 14'-9".

Example 2: measured height 14'-6", subtract 3" to create a safety margin 14'-3", and sign as 14'-3" (rounding down not required as already expressed to the nearest 3")

Thus, the maximum headroom that will normally appear on a sign is 16'-0".

## METRIC HEIGHTS

**7.12** To obtain the metric figure shown on signs, the bridge height should be measured to two decimal places, rounding down to the nearest 0.01 m. The following method is then used to calculate the appropriate signed height:

- (i) if the second decimal digit is 8 or 9, delete it and sign the bridge with the remaining whole number and the first decimal digit,
- (ii) if the second decimal digit is 7 or less, delete it and reduce the first decimal digit by 1. Sign the bridge with the remaining whole number and first decimal digit, as reduced,

e.g. measured height 4.19 m, sign as 4.1 m,

measured height 4.17 m, sign as 4.0 m.

The height shown on the sign must be to only one decimal place. The maximum headroom that will normally appear on a sign is 4.9 m.

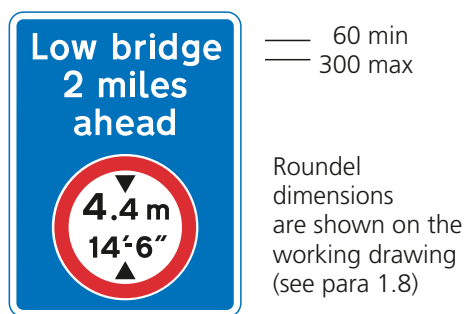
## DIVERSION SIGNING

**7.13** In order to reduce the risk of the driver of an overheight vehicle being confronted with an impassable bridge, it is important that properly planned diversion route signing is provided, certainly where a structure has a history of repeated strikes. In such a case, it is not sufficient to rely on warning signs alone. Diversion route signing may be incorporated into standard junction advance direction signs and flag-type signs, or separately mounted signs to diagram 818.4 or 818.5 may be provided (see paras 7.15 and 7.16), or both types of signing may be used together. The sign to diagram 818.3 is used to give advance warning of a non-arch bridge, but without indicating an alternative route. This sign might be appropriate in advance of any diversion route signing or on the immediate approach to a bridge (see para 7.18).

**7.14** The Regulations prescribe both map-type and stack-type advance direction signs for indicating alternative routes avoiding a low bridge (diagrams 2002 and 2003 on primary routes; 2107 and 2108 using Schedule 16 item 32 variants on non-primary routes). Prohibitory roundels are used where the restriction is mandatory (see para 7.17), otherwise the triangular warning signs shown in diagram 2002, or the dual height warning sign shown in diagram 530A, are used. The flag-type signs at the junction should also incorporate a warning sign, as in diagram 2027, or prohibitory sign as appropriate. Directional signs with a prohibitory roundel must also include a distance plate unless the restriction commences at the junction. For design details, see Chapter 7 paras 4.16 to 4.27, 5.60 to 5.81, 6.12 to 6.15, 7.6 to 7.10 and 11.16.

**7.15** An alternative route avoiding a mandatory height restriction may be signed using a sign to diagram 818.4, at the x-height indicated in Appendix A. The sign should be placed where the driver can see it in good time to make the necessary manoeuvre, before the advance direction sign for the next junction at which the routes advised are signed. It is essential that full route continuity signing is provided to the point where the original route is resumed.



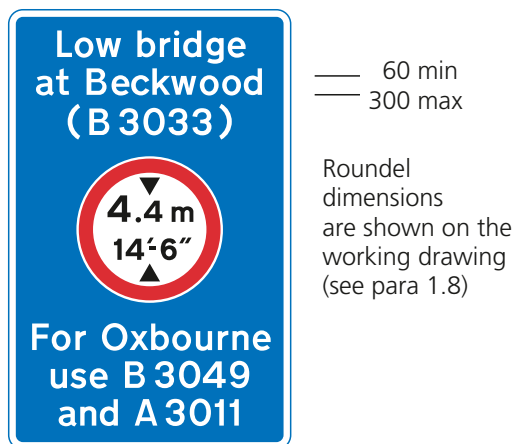


**818.3 Mandatory height limit at low bridge ahead**

"Low bridge" may be varied to "Height limit" or omitted (with the remaining legend placed below the roundel). An arrow may be added or substituted for the distance (with "ahead" omitted in each case).

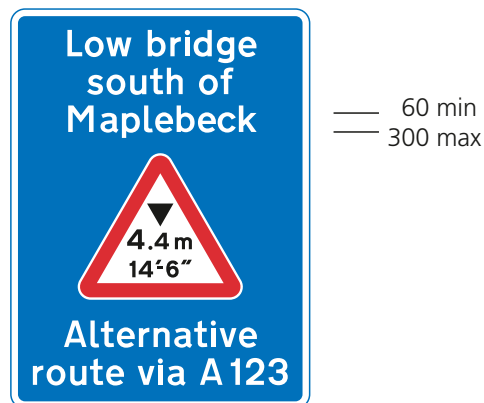
The distance may be varied (see Appendix C).

Details of the permitted variants are shown in the table below the diagram in the Regulations



**818.4 Mandatory height limit at low bridge ahead and indication of alternative route**

An arrow may be added above the roundel. "Low bridge" may be varied to "Height limit" or omitted, with the location varied as appropriate or changed to a distance (see Appendix C). "ahead" may be added after the distance when no arrow is shown. The alternative route may be varied as appropriate and may include a reference to a motorway junction. A diversion route symbol may be added. Details of the permitted variants are shown in the table below the diagram in the Regulations



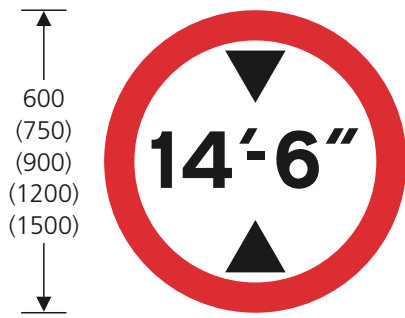
**818.5 Available headroom at low bridge ahead and indication of alternative route (Advance sign for an arch bridge)**

An arrow may be added above the diagram 530A symbol. The location may be varied as appropriate or changed to a distance (see Appendix C). "ahead" may be added after the distance when no arrow is shown. The diagram 530A symbol may be varied to diagram 530. The alternative route may be varied as appropriate and may include a reference to a motorway junction. A diversion route symbol may be added. Details of the permitted variants are shown in the table below the diagram in the Regulations

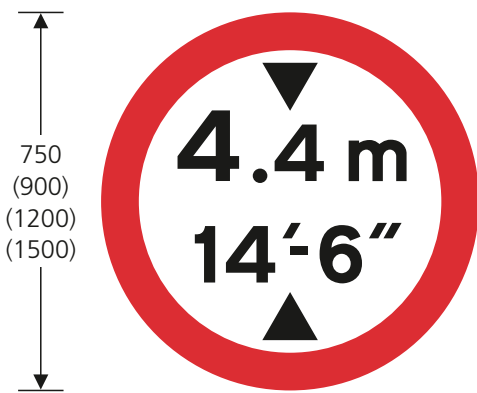
**7.16** At arch bridges, where the available headroom is indicated by signs to diagram 532.2, 532.2A, 532.3 or 532.3A, an alternative route may be signed using a sign to diagram 818.5, at the x-height indicated in Appendix A. As with mandatory height restrictions, the sign should be placed where the driver can see it in good time to make the necessary manoeuvre and full route continuity signing should be provided.

## NON-ARCH BRIDGES

**7.17** Mandatory signs should normally be used at non-arch bridges, as they can give more effective protection than warning signs. Traffic regulation orders are not required for mandatory height limit signs at a bridge, tunnel or similar structure over the highway (see direction 7(3)), but are required for limits imposed for environmental reasons.



629.2 Mandatory height restriction

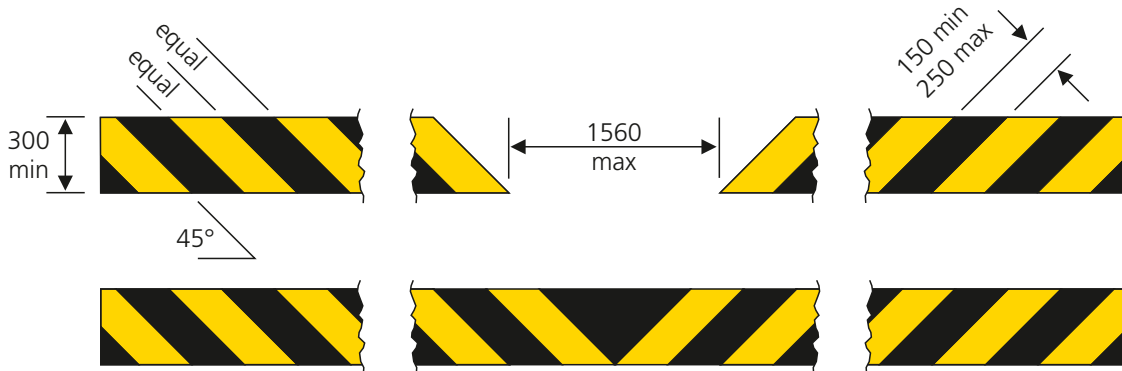


629.2A Mandatory height restriction (metric and imperial units)

*These signs may be used with diagram 530.2. The height may be varied (see Appendix C)*

7.18 Signs to diagram 629.2 or 629.2A may be used, but the latter, which shows both imperial and metric dimensions, is preferred. The signs should be mounted on the bridge, as a driver seeing a bridge with no height limit indicated might well assume the headroom to be at least 16'-6". They may also be placed at the roadside in advance of the bridge in accordance with direction 8 (in most cases a sign being required on each side of the road), but as it is an offence for drivers of overheight vehicles to pass these signs, they should not be placed where they would prevent legitimately-required access to premises or side roads. Even when diversion signing has been provided, it is still necessary to give proper advance warning of the height restriction. Signs to diagram 530 or 530A are not appropriate, as they give no indication of the prohibition. Diagram 818.3 (or diagram 818.4 if it is considered necessary to include the diversion route) should be used; it will sometimes be possible to indicate an escape route for drivers who have missed the diversion signs by siting this sign in advance of the last diversion or turning point before the bridge. If it is much further from the bridge than the usual warning distance indicated in Appendix A, another sign to diagram 818.3 or 818.4 may be required at the appropriate place. Diagram 818.3 or 818.4 may also be used to indicate a restriction in a side road by including an arrow on the sign (the legend "ahead" must not be used with the arrow). The signing on the approach to a non-arch bridge is shown in figure 7-2.

7.19 Although warning signs to diagram 530 or 530A may be mounted on non-arch bridges as an alternative to mandatory signs, this practice is not recommended.



530.2 Reduced headroom at a hazard

*May be used only in combination with diagram 530, 629.2 or 629.2A*

End of diversion route for overheight vehicles

Signing at structure

Diagram 629.2A plus conspicuity markings to diagram 530.2

Prohibitory signs, if appropriate (see para 7.18)

Diagram 629.2A

Note: If access is required to premises, these signs may be replaced by a single sign to diagram 818.3

Advisory sign in advance of last turning opportunity, if needed

Diagram 818.3

Advisory signing in advance of start of diversion route for overheight vehicles

Diagram 2002 or 2003  
(Diagram 2107 or 2108 on non-primary routes)

Diagram 818.4

Notes: (1) Either diagram 2002 etc. or 818.4, or both types of advisory signing, may be used as appropriate.

(2) Continuity signing is essential on the diversion route.

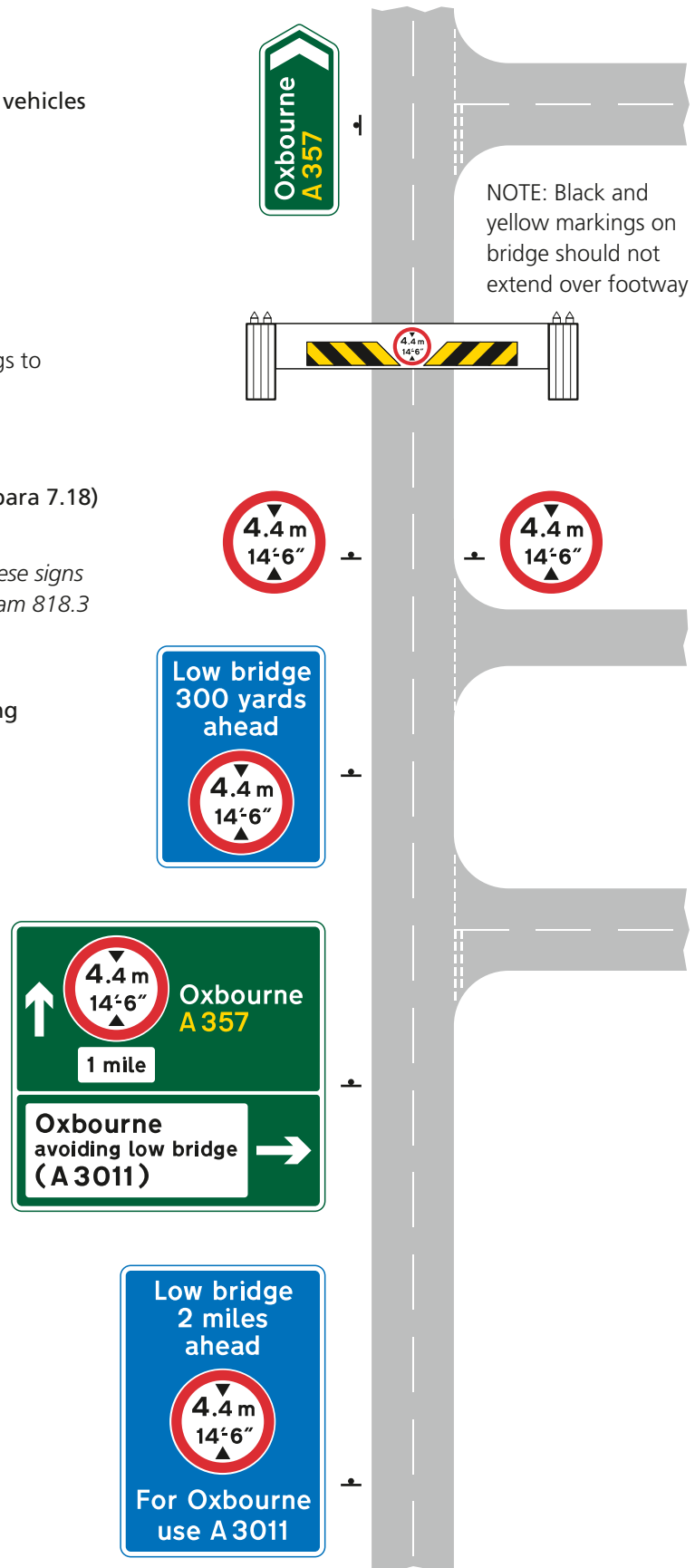


Figure 7-2 Signs on approach to a non-arch bridge with a diversionary route

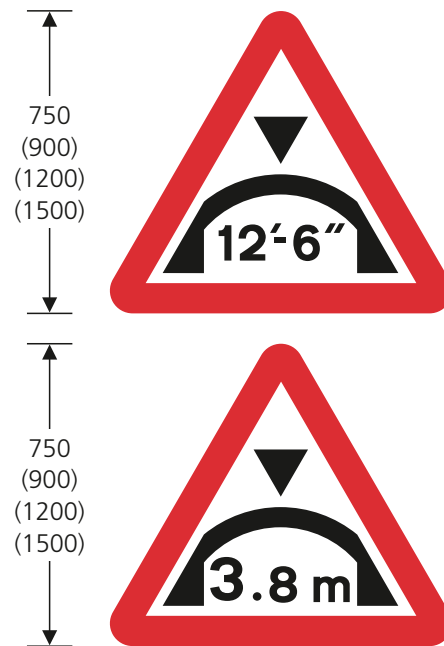
7.20 The conspicuity of the bridge can be significantly enhanced by use of the marking to diagram 530.2. Where the yellow parts of the marking are made of retroreflective material, they may also be fluorescent (see para 7.6). The first of the two alternative types, with a cut-out for the signs, should normally be used on the lowest part of the bridge elevation. If the construction of the bridge is such that signs cannot be located in this position, the second alternative should be used, with the signs mounted above.

### ARCH BRIDGES

7.21 Mandatory signs are not used at arch bridges, as the main risk to these comes from vehicles which, although low enough to pass through the central part of the arch, might strike the curved shoulder of the structure. See Chapter 5 (paras 22.5 to 22.10) for guidance on the use of road markings at arch bridges.

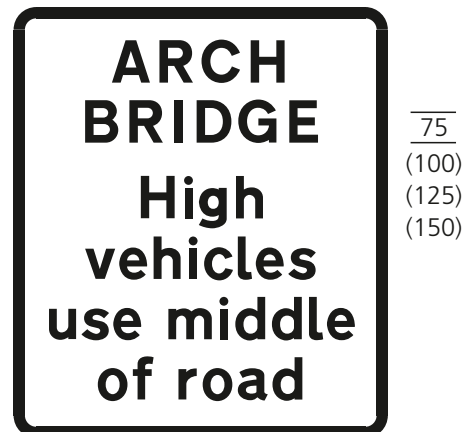
7.22 Arch bridges should be signed using diagram 531.1 and 531.2 (but see para 7.24). Signs to diagram 531.1 are always one size larger than normally required for a warning sign, with a minimum height of 750 mm. This is because a smaller legend than usual has to be used in order to accommodate the arch symbol. These signs are intended for use in advance of the bridge, and should normally be used on both approaches at the standard siting distances (see Appendix A). They should not be used on the bridge itself nor should they be incorporated in directional signs or the sign to diagram 818.5 where diagram 530 or 530A should be used. The signing on the approach to an arch bridge is shown in figure 7-3.

7.23 The chord marking to diagram 532.2 or 532.2A, or if appropriate the double chord to diagram 532.3 or 532.3A, should be used on the bridge structure. It should always be reflectorised, to make it easier to see at night. If the double chord is used, the triangular signs at the side of the arch should be the appropriate size for the road (see Appendix A), and those at the top of the arch one size larger. The height indicated on the warning sign to diagram 531.1 will be that for the chord above the centre of the road.



531.1 Available headroom at arch bridge ahead

*May be used with diagram 531.2, 572 or 573.  
The height may be varied (see Appendix C).  
The metric sign may be omitted but must not be used alone*



531.2 High vehicles to use middle of the road at arch bridge ahead

*May be used only in combination with diagram 531.1. An arrow may be added to the sign pointing either to the left or to the right*

End of diversion route for overheight vehicles



Signing at structure

Diagram 532.2A or 532.3A



Road markings if needed (see Chapter 5)

Final warning sign

Diagram 531.1 (see para 7.22 for location)

Diagram 531.2 if needed



NOTE: Black and yellow markings on bridge should not extend over footway

Additional sign in advance of last turning opportunity, if needed

Diagram 531.1 plus 572

Advisory signing in advance of start of diversion route for overheight vehicles

Diagram 2002 or 2003 (Diagram 2107 or 2108 on non-primary routes)

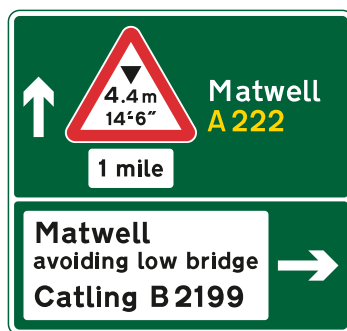


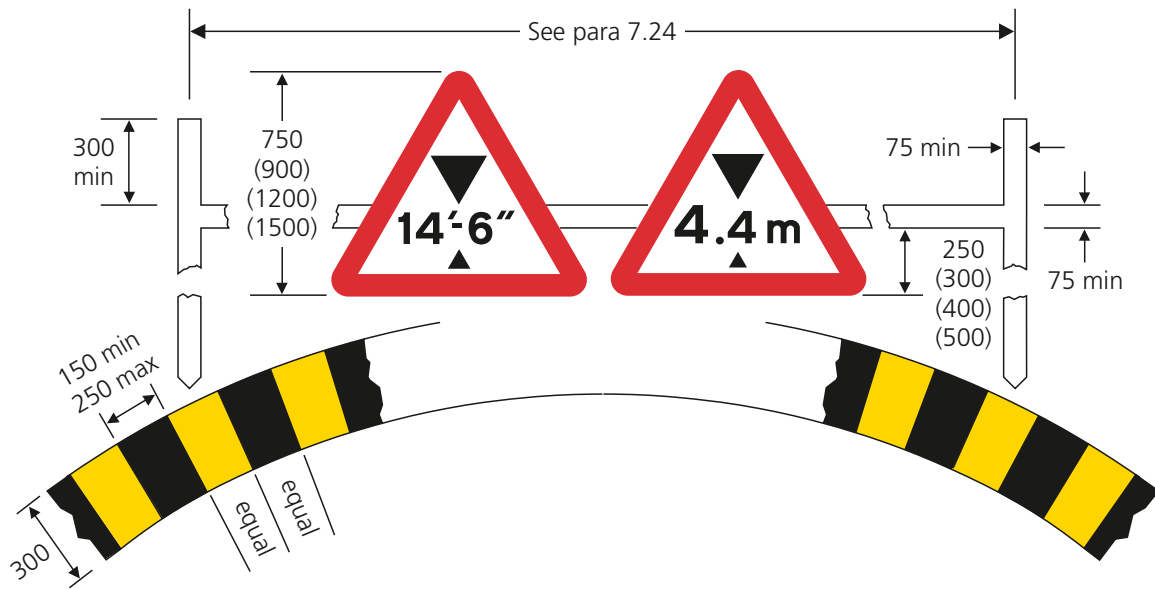
Diagram 818.5

Notes: (1) Either diagram 2002 etc. or 818.5, or both types of advisory signing, may be used as appropriate.

(2) Continuity signing is essential on the diversion route.

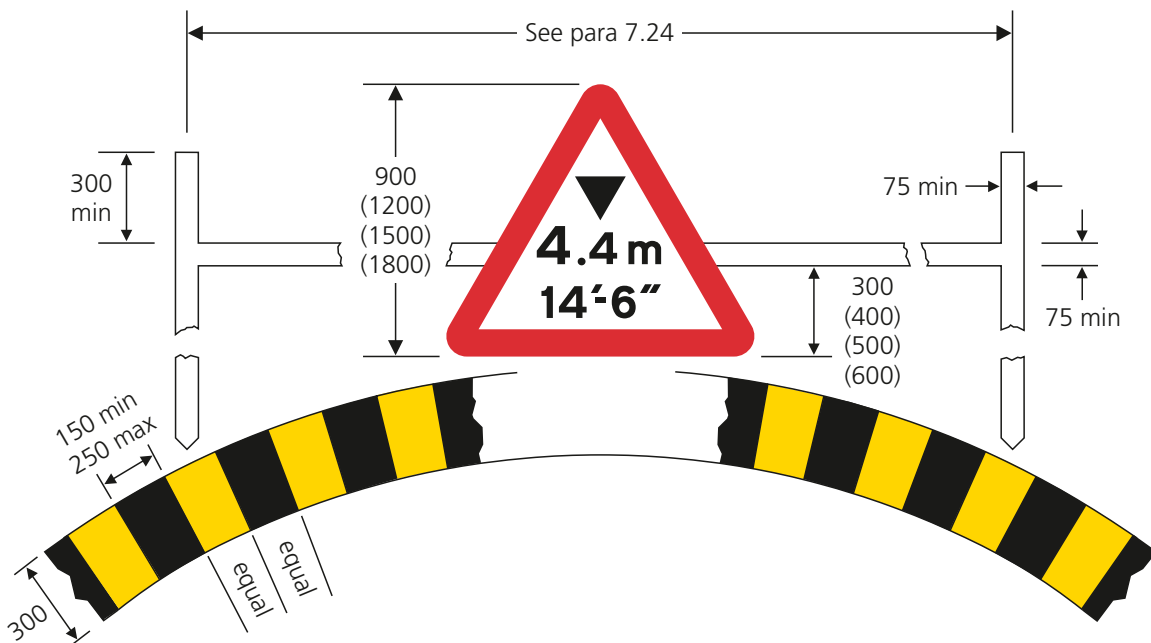


Figure 7-3 Signs on approach to an arch bridge with a diversionary route



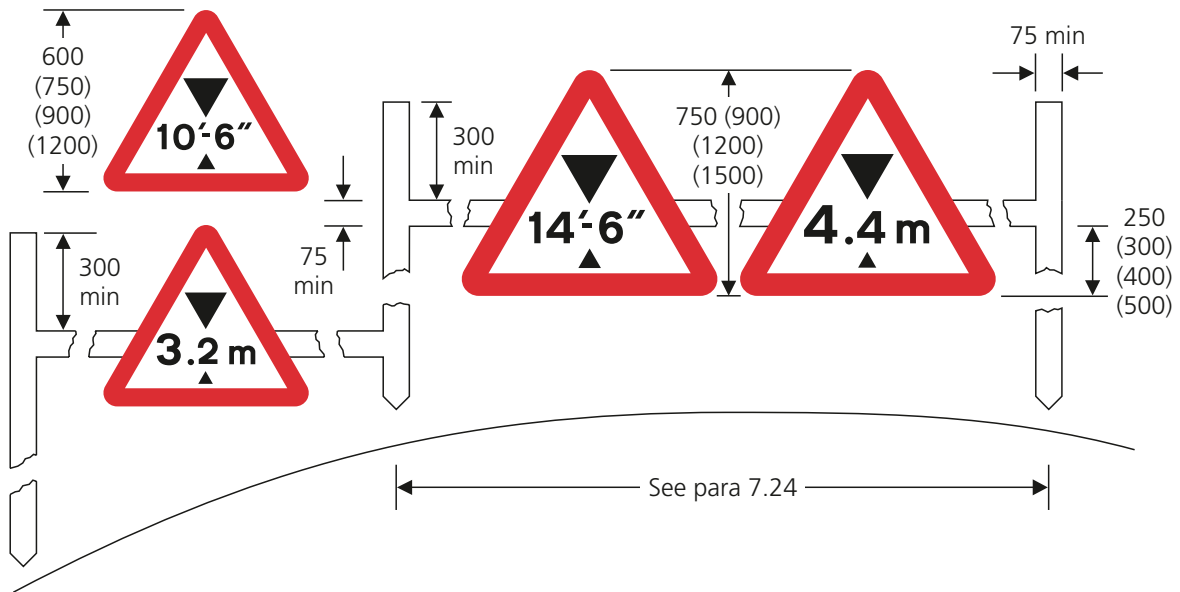
532.2 Maximum headroom at centre of arch bridge indicated by signs to diagram 530

*The black and yellow markings may be omitted. The metric sign may be omitted.  
The height may be varied (see Appendix C)*



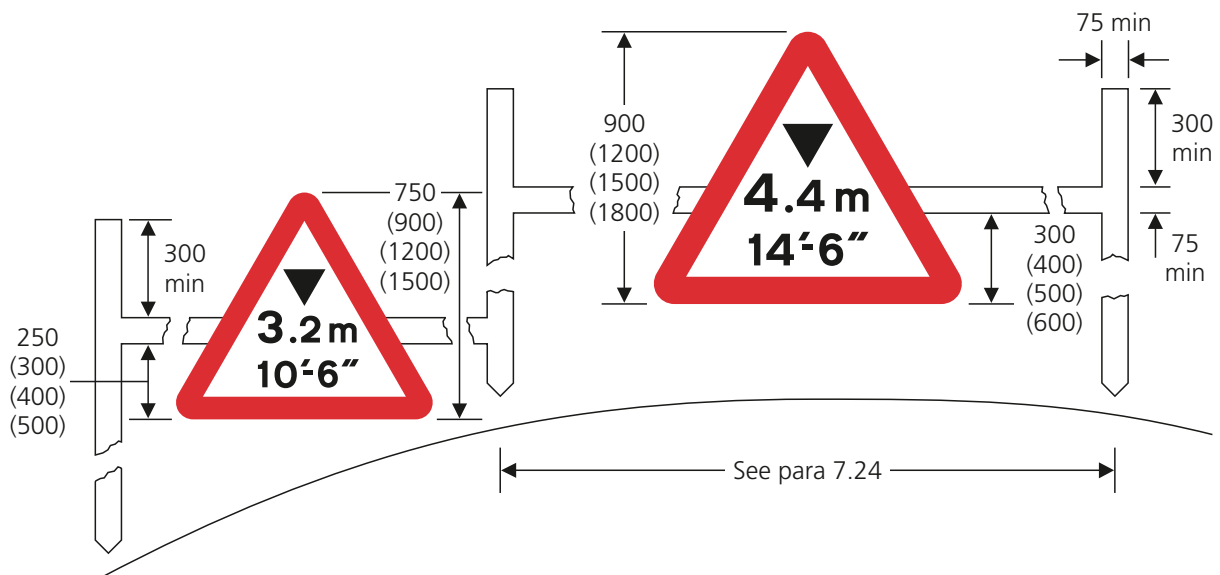
532.2A Maximum headroom at centre of arch bridge indicated by a sign to diagram 530A

*The black and yellow markings may be omitted. The height may be varied (see Appendix C)*



532.3 Maximum headroom at side and in centre of arch bridge indicated by signs to diagram 530

*The black and yellow markings shown in diagram 532.2 may be added.  
The metric signs may be omitted. The height may be varied (see Appendix C)*



532.3A Maximum headroom at side and in centre of arch bridge indicated by signs to diagram 530A

*The black and yellow markings shown in diagram 532.2A may be added.  
The height may be varied (see Appendix C)*

**7.24** The chord marking should indicate the available headroom over a width of not less than 3 metres. The height indicated on the warning signs, determined in accordance with paras 7.8 to 7.12, should be the lowest headroom between the chord limits. On a narrow bridge where the headroom decreases rapidly away from the centre, a 3 metre chord marking is appropriate. On a wide bridge with only a gradual reduction in headroom it might be possible to increase the chord width to 6 metres or more without excessively restricting the signed height, thus maintaining two-way operation for all vehicles that can pass under the bridge. In these circumstances, the warning sign to diagram 531.1 is unlikely to require the supplementary plate to diagram 531.2. Where 16'-6" (5.03 m) headroom is available over much of the carriageway width, but not all of it, diagram 532.3 or 532.3A should be used with the central signs varied to 16'-6" (5.0 m) and the signs on the side chords indicating the clearance available at the near side channel (see paras 7.10 and 7.11 for measurement of clearances). Black and yellow markings shown in diagram 532.2 or 532.2A should then be used over those parts of the carriageway where the clearance is below 16'-6", to give greater emphasis to the restricted height. It is recommended that the yellow parts of the marking should be retroreflective; they may also be fluorescent (see para 7.6). The chord markings shown in diagrams 532.3 and 532.3A may be used in circumstances other than described above, particularly on wide roads where there are two lanes in one or both directions, with the side chord positioned over the left hand lane. Side chords are also useful where vehicles with a height well below that shown for the centre of the road might strike the bridge if keeping close to the left hand side of the carriageway.

### COMPOSITE BRIDGES

**7.25** Some bridges originally built as arches have been adapted with the addition of girders or beams. Where the arch is the lowest part, the whole structure should be signed as an arch bridge. Black and yellow striped plates (to highlight the profile of the arch) should be suspended from the bridge beam, together with further plates on the arch itself.

**7.26** Where the beam is lower than any part of the arch, the whole structure should be signed as a non-arch bridge and plates with black and yellow markings to diagram 530.2 suspended from the arch at the height of the beam. Similarly, where two adjacent beam bridges have different headroom, the plates should be located on the higher bridge at the height of the lower one.

**7.27** Experience has shown that these suspended plates will themselves be struck from time to time and that rigidly-mounted aluminium substrates are not suitable. Rubber or other flexible material should be used for the backing, suspended by means of chains or hinges fixed securely to the bridge structure by a method agreed with the bridge owner. The plates should not be fixed rigidly by screws or bolts to the face of the bridge, as there is a greater risk than with flexibly-suspended plates of them being dislodged and falling onto vehicles on the road beneath. The use of rubber-backed plates will help to avoid annoyance to nearby residents from the noise of hanging metal plates striking the bridge structure in wind or vehicle slipstream. It is recommended that the yellow parts of the marking should be retroreflective; they may also be fluorescent (see para 7.6). When the signs are lit, the plates should also be lit whenever practicable. This is particularly helpful where a girder bridge is followed by a more restrictive arch bridge.

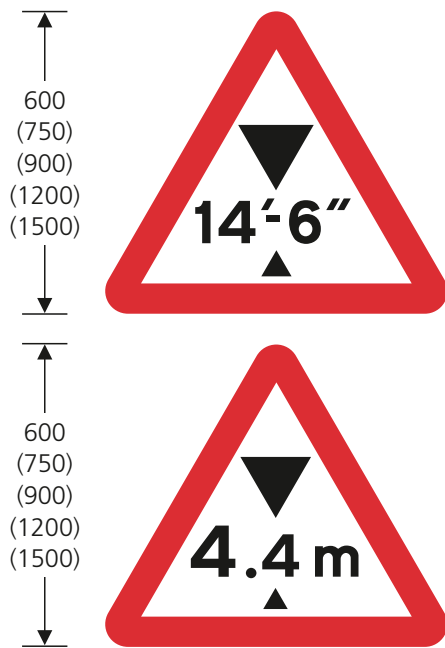
### OVERHEAD POWER CABLES

**7.28** For guidance on signing overhead power cables, see paras 21.9 to 21.12.

### OVERHANGING BUILDINGS

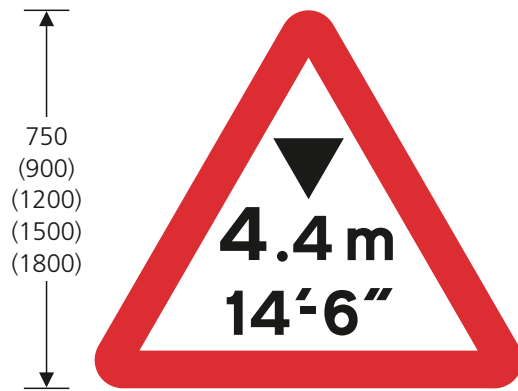
**7.29** Where an overhanging building or other structure causes a restriction over part of the carriageway, the plate to diagram 530.1 should be used with diagram 530 or 530A. A distance may be added. Where the building is in another road, an arrow may be added, pointing horizontally to the left or to the right. Details are given on the working drawing (see para 1.8).





530 Available headroom with imperial and metric units shown on separate signs

*May be used with diagram 530.1, 530.2, 572 or 573. The height may be varied (see Appendix C). The metric sign may be omitted or placed to the right of the imperial sign, but must not be used alone*



530A Single sign showing available headroom in both metric and imperial units

*May be used with diagram 530.1, 530.2, 572 or 573. The height may be varied (see Appendix C)*



530.1 Building overhanging part of carriageway

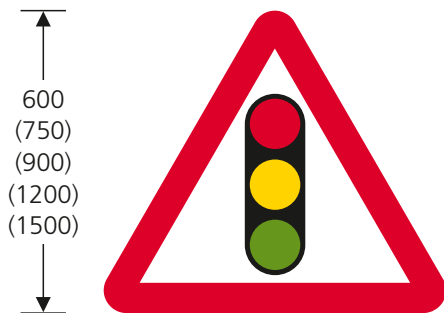
*May be used only in combination with diagram 530 or 530A. A distance, an arrow or both may be added. "building" may be varied to "buildings" or to "structure"*

## 8 TRAFFIC SIGNALS

8.1 The traffic signals warning sign is shown in diagram 543. A plate to diagram 573 (see section 18) is used where the signals are located along another road. When used on a dual carriageway road, the signs should be duplicated on the central reservation.

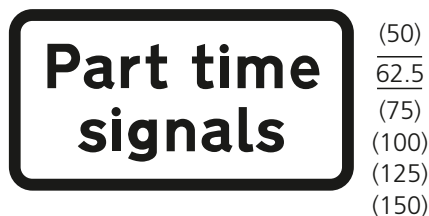
8.2 The sign may be used with all three-aspect type traffic signals, including Pelican, Toucan and Puffin crossings and portable traffic signals used at road works. It is not for use with wig-wag signals to diagram 3014, where diagram 563.1 or 773 should be used with the appropriate warning sign (see sections 17 and 21). Nor should it normally be used where visibility is impaired only by parked vehicles, when the imposition of waiting and loading restrictions should be considered. The guidance in this section applies only to permanent installations. See Chapter 8 for guidance in respect of temporary installations.

8.3 Diagram 543 should generally be used only where the visibility distance of the signals is less than that specified in table 8-1. The distances quoted make some allowance for the hazard being the back of a queue rather than the stop line. Where a sign is provided, it should be placed at the distance from



543 Traffic signals ahead

May be used with diagram 543.1, 547.8, 572, 573 or 7030



543.1 Part time signals

May be used only in combination with diagram 543, 3000, 3000.7, 3000.8, 3000.9 or 3000.10. "Part time" may be varied to "Peak hour". An indication of distance and an arrow may be added

the stop line indicated in the right hand column of table 8-1; a distance plate to diagram 572 should not then be necessary. Where distance plates are used, these must be in yards to the nearest 10 yards (see Appendix C). For speeds over 50 mph, signs should be provided regardless of visibility distances, at the locations indicated in column 4 of Appendix A.

Table 8-1 Visibility distance criteria

| 85th percentile speed (mph) | Visibility distance of signals (m) |
|-----------------------------|------------------------------------|
| Up to 30                    | 65                                 |
| 31 to 35                    | 80                                 |
| 36 to 40                    | 100                                |
| 41 to 45                    | 125                                |
| 46 to 50                    | 150                                |
| Over 50                     | Should be used at all sites        |

8.4 Where map-type advance direction signs are provided on the approach to a signal-controlled roundabout, diagram 543 (with the appropriate plate) should be installed, as drivers might not otherwise expect the signals (see also para 2.13).

8.5 The "Part time signals" plate (diagram 543.1) should always be used where the signals are in use for a period of less than 24 hours. The "Peak hour" variant may be used where appropriate. The plate should be used on each signal post, and in combination with diagram 543 on the approaches to the junction.

8.6 The plate to diagram 7030 "Temporary traffic control ahead" may be used only with temporary traffic signals for convoy working at road works, in combination with the sign to diagram 543. Detailed guidance can be found in TA 63, in Volume 8 of the Design Manual for Roads and Bridges (see para 1.3).

8.7 Diagram 7014 (see para 1.17 for guidance on size) indicating "NEW TRAFFIC SIGNALS AHEAD" may be used in advance of a new installation. Direction 37 restricts its use to a period no longer than 3 months. Similarly, variants indicating "SIGNAL PRIORITIES CHANGED" or "SIGNAL TIMINGS CHANGED" may be erected at altered installations as appropriate for up to 3 months.

**8.8** When maintenance work is being carried out on traffic signals, the sign to diagram 7010.1 varied to "TRAFFIC SIGNAL MAINTENANCE" may be displayed. If the traffic signals are not operating, signs to diagram 7019 may be erected. These are erected on the signal post and must be reflectorised if not directly lit (see para 1.38).

# 9 PEDESTRIANS

## PEDESTRIAN CROSSINGS

9.1 The sign to diagram 544 is for use only at Zebra crossings. A plate to diagram 7014 (see para 1.17) indicating "NEW ZEBRA CROSSING AHEAD" may be used at a new installation; its use is restricted by direction 37 to a period no longer than 3 months. Zebra crossings should not be installed on roads where the 85th percentile speed is 35 mph or more (see para 4.2.3 in Local Transport Note 1/95: The Assessment of Pedestrian Crossings). Diagram 544 must not be used at Pelican, Puffin or Toucan crossings, where diagram 543 (see section 8) is appropriate, nor where pedestrians cross the road but no formal crossing exists. In the latter case, on high-speed roads, diagram 562 may be used together with the supplementary plate to diagram 563 "Pedestrians crossing" (see para 17.4).

9.2 Diagram 544 may be used in combination with a distance plate to diagram 572 when it is necessary to site it at a distance much different to that specified in Appendix A. When the crossing is in another road leading from a junction ahead, a plate to diagram 573, with or without a distance, may be used.

9.3 Signs to diagram 544 should be used only when the visibility of the crossing is impaired by a bend or a hump in the road. Signs should not be needed if the visibility of both beacons at a Zebra crossing is greater than the distance shown in table 9-1. If the sight lines to a Zebra crossing are obscured by parked vehicles, the making of a waiting prohibition order should be considered.

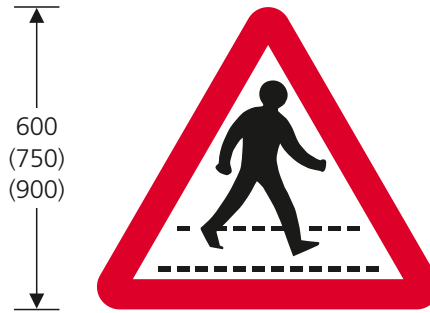
Table 9-1

| Speed limit<br>(mph) | Visibility distance of both beacons<br>(m) |
|----------------------|--|
| 30                   | 45   |
| 40                   | 90   |

## VULNERABLE PEDESTRIANS

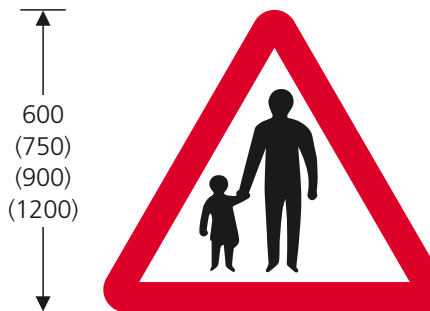
9.4 Where pedestrians frequently use a road without proper footways, diagram 544.1 may be used to warn drivers of the likely presence of pedestrians in the carriageway. If a footway stops and resumes after some interval, the supplementary plate to diagram 547.3 may be used, with the distance varied to show the length of the road which is without a footway.

9.5 The sign to diagram 544.2 is used to warn of the likely presence of frail or disabled people. Its use should be restricted to sites where numbers of slow-moving pedestrians are likely to cross a road other than at a Zebra or signalled crossing. This might be near sheltered housing or nursing homes, where drivers need to be reminded that a pedestrian in the road ahead might be frail or blind and need more time to cross than an able-bodied person would.



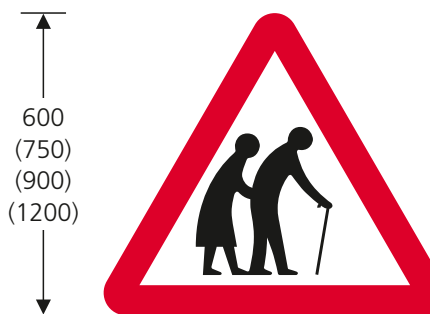
544 Zebra crossing ahead

May be used with diagram 547.8, 572 or 573



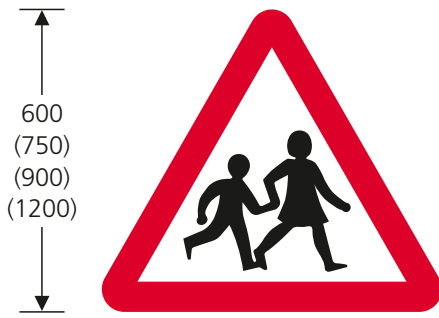
544.1 Pedestrians in road ahead

May be used with diagram 547.3, 572 or 573



544.2 Frail or disabled pedestrians likely to cross road ahead

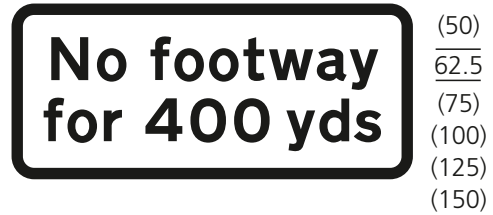
May be used with diagram 547.4, 572 or 573



545 Children going to school or playground

May be used only in combination with diagram 546, 547.1, 547.2, 547.3 or 547.7. When used with 546, 547.1 or 547.7 may also be used with diagram 4004

9.6 Where appropriate, the sign to diagram 544.2 may be accompanied by a supplementary plate to diagram 547.4 indicating "Disabled people" or its permitted variant "Blind people". A distance, an arrow (pointing horizontally to the left or to the right) or both may be added. Details are given on the working drawings - see para 1.8.



547.3 No footway for distance indicated

May be used only in combination with diagram 544.1 or 545. The distance may be varied (see Appendix C)



546 School ahead



547.4 Disabled pedestrians likely to cross road ahead

May be used only in combination with diagram 544.2. "Disabled" may be varied to "Blind". A distance, an arrow or both may be added



547.1 School crossing patrol ahead



547.2 Children's playground ahead

These plates may be used only in combination with diagram 545. A distance, an arrow or both may be added



547.7 Disabled children likely to cross road ahead

May be used only in combination with diagram 545. "Disabled" may be varied to "Blind" or "Deaf". A distance, an arrow or both may be added

## CHILDREN

9.7 The sign to diagram 545 is used to warn of the likelihood of encountering children in the road ahead, going to a school or playground. It must be used in combination with one of the supplementary plates to diagram 546, 547.1, 547.2, 547.3, or 547.7 (direction 20(2)). When used in combination with diagram 546, 547.1 or 547.7 it may also be combined with the light signals shown in diagram 4004. It should be sited to ensure adequate warning is given; this might require a greater distance than specified in Appendix A for signs warning of fixed hazards. A distance, an arrow (pointing to the left or to the right) or both may be added to the plate in accordance with the working drawings (see para 1.8).

9.8 When combined with 546 or 547.1, the sign may be provided where children cross the road on their way to or from school, or from one part of a school to another. If the school or playground caters exclusively or predominantly for disabled, blind or deaf children, the plate to diagram 547.7 (suitably varied) should be used with the sign to diagram 545.

9.9 Where children going to school use roads without proper footways, it may be necessary to warn drivers of their likely presence in the road. A sign to diagram 545 may be used with a supplementary plate to diagram 547.3.

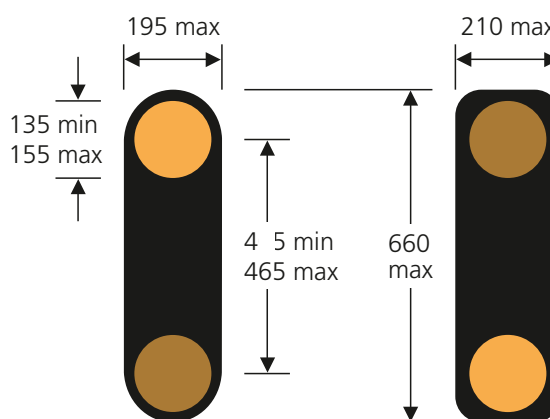
9.10 When used with the "Patrol" plate (diagram 547.1) the sign to diagram 545 warns of a crossing place where children are supervised by a warden appointed by the local authority and operating with the sign prescribed by the School Crossing Patrol Sign Regulations. "Patrol" signs should not be used at signalled or Zebra crossings, as drivers expect to stop at formal crossings whether or not a warden is present.

## FLASHING AMBER LIGHTS

9.11 Flashing amber lights (diagram 4004) are used to give emphasis to the warning sign where the 85th percentile speed exceeds 35 mph, or on a busy road where a driver's attention is likely to be fully occupied. The lights may be used only when diagram 545 is used together with diagram 546, 547.1 or 547.7 and the crossing point is in use (whether or not it is supervised). See regulation 50 (40 in the Northern Ireland Regulations) and direction 55(1). Lights should not be used near level crossings, traffic signals,

Pelican, Puffin, Toucan or Zebra crossings if this might cause confusion or distraction. They should never be used to warn of children crossing at signalled or Zebra crossings. Guidance on the possible need to sign such crossings can be found in section 8 (signalled crossings) and para 9.3 (Zebra crossings).

9.12 Where conditions at a patrol site justify flashing lights and there is another patrol site situated within 500 metres that does not, consideration should be given to the provision of lights at both or neither site.



4004 Flashing amber lights  
(Alternative types)

*May be used only in combination with diagram 545 together with diagram 546, 547.1 or 547.7*

## HUMPED CROSSINGS

9.13 Pelican and Zebra crossings may be installed on road humps. Diagram 547.8 may be used together with a sign to diagram 543 or 544 as appropriate. Further guidance on signing road humps can be found in section 13.



547.8 Zebra crossing or signal-controlled crossing on road hump ahead

*May be used only in combination with diagram 543 or 544. A distance, an arrow or both may be added*

## 10 ANIMALS AND FARM TRAFFIC

### GENERAL

10.1 The signs in this section are used to give warning of wild animals, farm animals, horses being taken or ridden along or across a road, or of straying animals from neighbouring unfenced land. The onus is normally on those in charge of farm animals or horses to ensure that their movement is carried out safely; nevertheless the signs may be used at places where animals regularly cross or move along a road, but where visibility is poor.

10.2 Where a sign is provided, but the danger is not likely to be present throughout the year (e.g. in winter months when animals are not normally driven across a particular road) traffic authorities should arrange for the sign to be covered during that time, in order to preserve its credibility.

10.3 If animals will be encountered only over a known, determinate length of road, the addition of a distance plate, e.g. "For 500 yds" (diagram 570) will be appropriate, but the signs may need to be repeated if the danger exists over a considerable distance. It will often be found that animals wander onto the highway not at completely random points, but in particular areas and warning signs should be erected accordingly. See section 18 for further guidance on the use of distance plates.

### CATTLE CROSSINGS

10.4 The cattle sign to diagram 548 will generally provide sufficient warning of cattle crossings. However, at sites with restricted visibility or where heavy traffic flows make it difficult to herd cattle across the road, the sign to diagram 4005 (which comprises the sign to diagram 548 and flashing amber lights) may be used.

10.5 A warning sign to diagram 548 with a plate to 548.1 must be used in advance of a cattle crossing where flashing lamps are used (direction 55(2)).

10.6 Such signing is not intended as a solution for anticipated problems on planned new roads, major improvements, or where at other sites the movement of cattle would frequently obstruct traffic for a period of more than three minutes. Nor is a surface crossing appropriate where the traffic flow exceeds 30,000 vehicles per day. In such cases other measures such as a segregating facility should be considered.



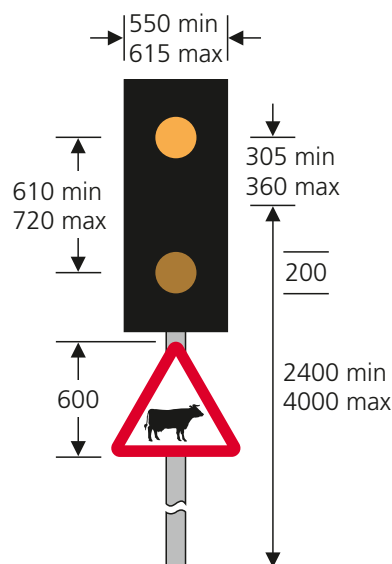
548 Cattle

May be used with diagram 548.1, 570 or 4005



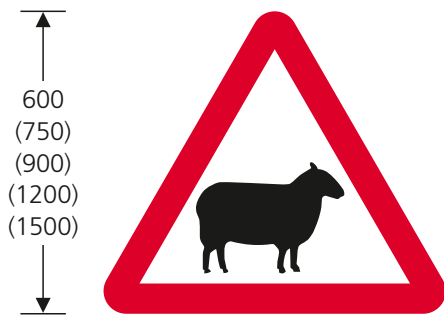
548.1 Signalled cattle crossing ahead

May be used only in combination with diagram 548 placed in advance of diagram 4005. The distance may be varied (see Appendix C). An arrow may be added pointing to the left or to the right

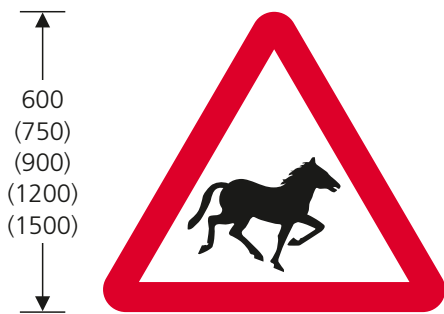


4005 Signalled cattle crossing

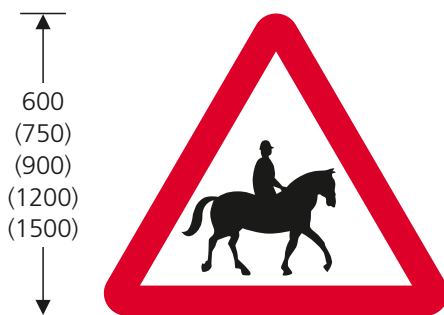
May be used only in conjunction with diagrams 548 and 548.1 placed in advance of this sign



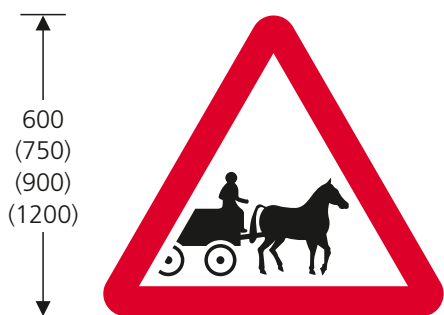
549 Sheep



550 Wild horses



550.1 Accompanied horses



550.2 Horse-drawn vehicles

The above signs may be used with diagram 570.  
Diagram 550.1 may also be used with diagram 572  
or 573

10.7 Criteria for the provision of flashing amber lights are set out in table 10-1. These are based on the minimum desirable stopping sight distance specified in TD9, in Volume 6 of the Design Manual for Roads and Bridges (see para 1.3). Lights are not recommended unless the driver's field of clear visibility is less than the distance shown, or the traffic flow exceeds 10,000 vehicles per day on roads where the 85th percentile speed exceeds 30 mph.

Table 10-1 Cattle crossing places

| 85th percentile speed (mph) | Visibility distance (m) |
|-----------------------------|-------------------------|
| Up to 30                    | 70                      |
| 31 to 40                    | 110                     |
| 41 to 50                    | 150                     |
| 51 to 60                    | 200                     |
| Over 60                     | Not suitable            |

10.8 Where conditions at a cattle crossing site meet these criteria and, on the same road within approximately half a mile there is another site which does not meet them, consideration should be given to the provision of flashing lamps at both sites.

10.9 The flashing lamp units should be erected on both approaches as close as practicable to the start and finish points of the cattle journey. The mid point between the flashing lamps must be between 2.4 m and 4 m above the adjacent carriageway. This allows a minimum headroom of 2.1 m to be maintained when the assembly is mounted over a footway.

**OTHER ANIMAL SIGNS**

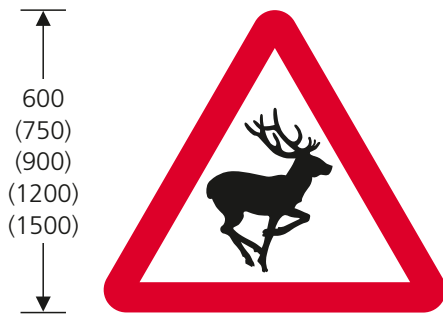
10.10 Signs to diagram 549 (sheep), 550 (wild horses) and 551 (wild animals) may be used wherever such animals are likely to be found in the road (see also para 10.3).

10.11 Diagram 550.1 warns of accompanied or ridden horses or ponies (as opposed to the wild or stray variety indicated by the sign to diagram 550) where numbers of horses are frequently walked or ridden along or crossed over the road. Warning of horses crossing the road ahead, e.g. where a bridleway crosses the road, can be given by adding the diagram 572 distance plate (or 573 if the crossing is in another road). Diagram 550.2 is used to warn of horse-drawn vehicles in the road ahead.



Table 10-2 Horse crossing places

| 85th percentile speed (mph) | Visibility distance (m) |
|-----------------------------|-------------------------|
| Up to 40                    | 80                      |
| 41 to 50                    | 110                     |
| 51 to 60                    | 150                     |
| Over 60                     | 200                     |



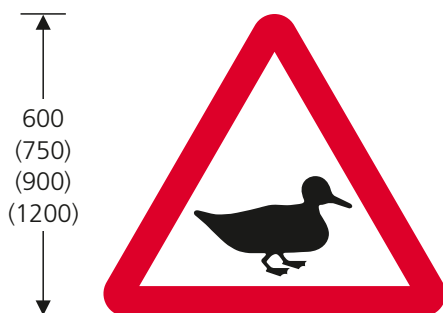
551 Wild animals

May be used with diagram 570



551.1 Migratory toad crossing

May be displayed only between January and May.  
May be used with diagram 570



551.2 Wild fowl

May be used with diagram 570

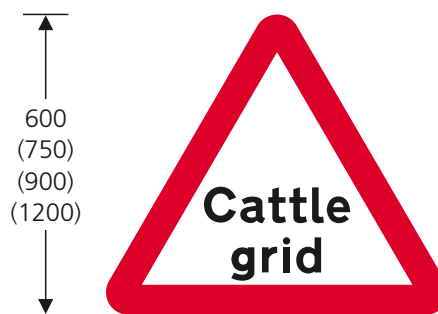
10.12 Use of diagram 550.1 to indicate an informal crossing place should normally be considered only where the visibility distance is less than specified in table 10-2. These distances are based on one step below the minimum desirable stopping sight distance (see para 10.7).

10.13 The sign to diagram 551.1 may be used only at a site which is approved as a migratory toad crossing by or on behalf of the Secretary of State (see para 1.2) as a migratory toad crossing. A list of currently approved sites is available from the Froglife Trust (e-mail info@froglife.org). The sign may be accompanied by the distance plate shown in diagram 570. It may be displayed only during the months of January to May (direction 28). Signs must be removed or covered at other times of the year; it is recommended that flap-type signs be used to facilitate this. Traffic authorities that neglect their statutory responsibilities in this regard undermine the effectiveness of the sign.

10.14 The sign to diagram 551.2 may be used where wild fowl are habitually found in the road, such as sites near ponds and watercourses. It may be combined with diagram 570, displaying a distance, e.g. "For 150 yds", in accordance with Appendix C.

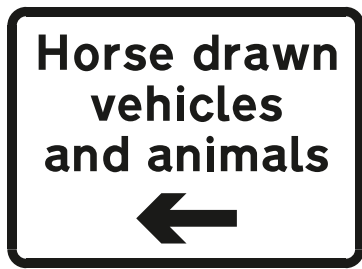
**CATTLE GRIDS**

10.15 A cattle grid on a public road should always be preceded by the cattle grid warning sign to diagram 552, as it might otherwise catch drivers unawares. Grids are especially hazardous for two-wheeled traffic. Signs should normally be sited at the standard distances set out in Appendix A. The plate to diagram 553 indicating the direction of the by-pass for horse-drawn vehicles or accompanied animals can



552 Cattle grid

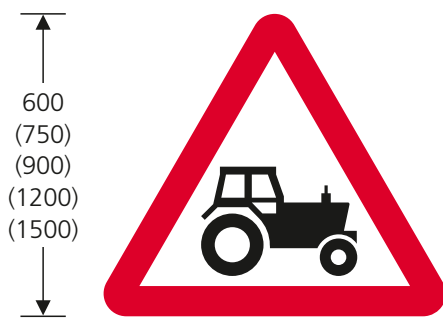
May be used with diagram 553, 572 or 573



50  
(62.5)  
(75)  
(100)

553 By-pass of cattle grid

May be used only in combination with diagram 552.  
The direction of the arrow may be reversed



553.1 Agricultural vehicles

May be used only in combination with the plate  
to diagram 553.2



50  
(62.5)  
(75)  
(100)  
(125)  
(150)

553.2 Agricultural vehicles

May be used only in combination with  
diagram 553.1. "Farm traffic" may be varied  
to "Wide vehicles" or "Tractors turning".  
The word "for" and a distance may be added

accompany the sign if the entrance to the by-pass is reasonably close to the grid. Otherwise a duplicate sign to diagram 552 plated with 553 should be placed at the entrance, with a plate to diagram 572 mounted directly below the triangular sign indicating the distance to the grid. If the grid is in another road, the advance warning sign should be accompanied by the plate to diagram 573.

### FARM TRAFFIC

**10.16** The sign to diagram 553.1 may be used wherever farm tractors or other agricultural vehicles frequently travel in the road at low speed, turn into or out of an entrance or cross a road. It may be particularly appropriate where visibility of an access or of turning vehicles is inadequate, or such vehicles turn unexpectedly across high-speed roads. The sign must always be used with a plate to diagram 553.2, which may read "Farm traffic", "Wide vehicles" or "Tractors turning". Where there are two entrances between which vehicles regularly travel, an indication of the distance over which the hazard extends may be added to the plate, e.g. "for 250 yds", in accordance with Appendix C.

### GATES

**10.17** The sign to diagram 554 (see section 11) may be varied to "Gate" or "Gates" as appropriate when used in a road which has gates installed, usually for the control of farm animals. As drivers are likely to have to stop in order to open the gate, the signs should normally be supplemented by a distance plate to diagram 572 or 573. A plate to diagram 570, e.g. "For 2 miles" may be used with the variant "Gates".

# 11 WATER

## FORDS AND FLOODS

11.1 The "Ford" sign, diagram 554, should be used at all fords, even those which dry up in summer. The sign should also be placed at the entry to the road leading to the ford, accompanied by a distance plate to diagram 572 or 573 as appropriate (see section 18). Where a road is subjected to frequent flooding, the "Ford" sign may be used with the diagram 563 plate "Road liable to flooding".

11.2 When diagram 554 is varied to "Flood" or (in the case of a fire or explosion hazard) "No smoking", it may be displayed only for as long as the hazard continues to exist or is expected to recur in the near future. The "Flood" variant may be accompanied by a distance plate to diagram 572 or 573 and should be followed, beyond the flooded length of road, by a "Try your brakes" sign (diagram 554.1). If the water depth makes the road impassable, "ROAD AHEAD

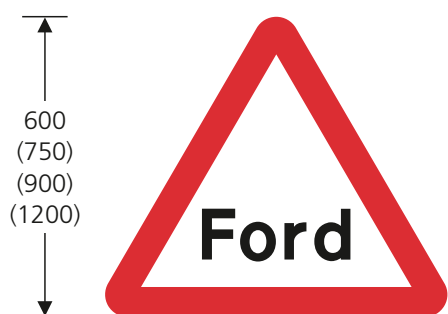
CLOSED" (diagram 7010.1), placed at each end of the closure at junctions where traffic can be diverted, would be more appropriate.

11.3 The "Try your brakes" sign should also be installed on the exit side of a ford. Given the likely minor status of the road, it will usually ensure adequate warning if these signs are mounted on the reverse of the "Ford" signs.

11.4 This sign may also be used with signs associated with steep hills and escape lanes (see section 6). The largest size (1500 mm) is for use with these signs, not at fords.

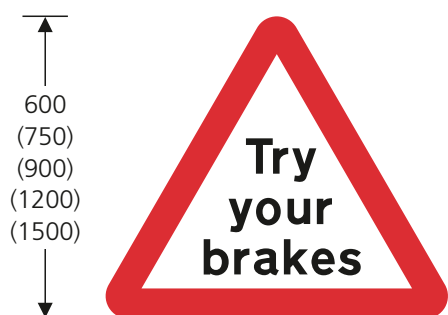
11.5 Depth gauges, diagrams 826 and 826.1, should be provided at fords or locations where flooding is known to be a persistent problem. The zero level is the lowest part of the carriageway. Gauges should be sited so that the depth of water can be seen by road users on both approaches.

11.6 The imperial (diagram 826) or imperial/metric (diagram 826.1) version of the depth gauge may be used, but metric units must not be used alone.



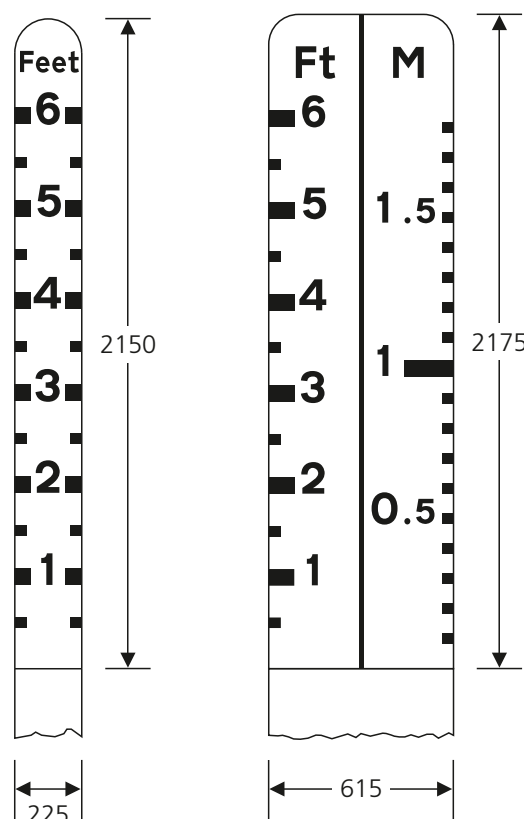
554 Ford

*May be used with diagram 563 (when varied to "Road liable to flooding"), 570 (when 554 is varied to "Gates"), 572 or 573. "Ford" may be varied to "Flood", "Gate", "Gates" or "No smoking"*



554.1 Try your brakes

*May be used with hill signs to diagram 526 or 817.2*



826

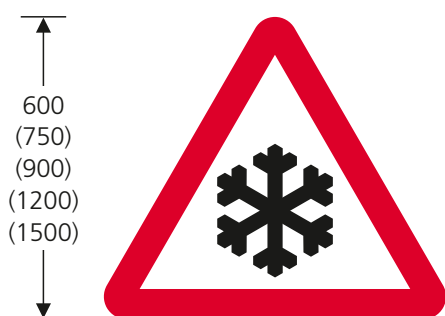
826.1

Depth gauges

**ICE AND SNOW**

**11.7** The “Ice” signs, diagrams 554.2 and 554.3, or the “Snowdrifts” variant, are intended for use as temporary signs when a route is unusually dangerous as a result of extensive icing or heavy snowfalls. The signs must be removed when conditions return to normal (direction 39(3)). When indicating “Ice”, one size larger x-height should be used to compensate for the short word, which would otherwise result in a very small plate. The variant “Snowdrifts” should be at the normal x-height for the road (see Appendix B).

**11.8** The “Ice” (or “Snowdrifts”) plate must never be used alone. It must be used with one of the following signs: 554.2, 622.1A (goods vehicle weight limit), 622.4 (No articulated vehicles), 629 (width limit, imperial units), 629A (width limit, metric and imperial units), 629.1 (length limit) or 632 (no overtaking). The regulatory signs are used when snow or ice conditions make it unsafe for the prohibited type of vehicle to use the road, or where, in the case of diagram 632, overtaking would be hazardous.



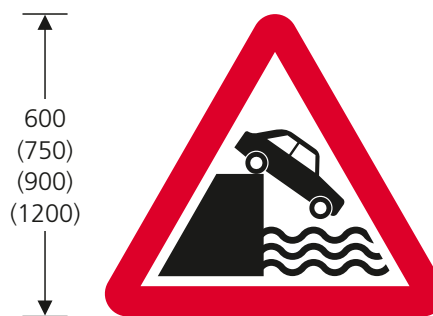
**554.2 Risk of ice or packed snow**

*May be used only in combination with diagram 554.3*

**QUAYSIDES AND WATER COURSES**

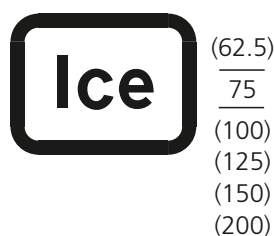
**11.9** The quayside or river bank sign, diagram 555, should be used wherever a public road approaches an unbarriered quayside or river bank. In order to break up the straight ahead view at such locations and to give greater emphasis, hazard markers to diagrams 560 or 561, chevrons to diagram 515, or appropriate direction signs may be mounted to face traffic that might be at risk.

**11.10** The water course sign, diagram 555.1, is intended for locations where a road runs alongside a water course of sufficient depth to be a danger if a vehicle leaves the carriageway. This may be important if the water surface cannot easily be seen, e.g. because of obscuration by vegetation, or if the road is liable to flooding and there is difficulty in distinguishing between carriageway and water course. A sign is not necessary if the road edge is kerbed or if a safety fence is provided. Where the risk is to vehicles parking alongside a water course, e.g. at a quayside, diagram 555 will be more appropriate.



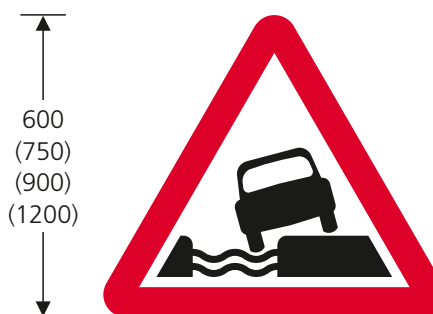
**555 Quayside or river bank**

*May be used with diagram 572 or 573*



**554.3 Ice ahead**

*May be used only in combination with diagram 554.2, 622.1A, 622.4, 629, 629A, 629.1 or 632. “Ice” may be varied to “Snowdrifts”. “for” and a distance may be added*



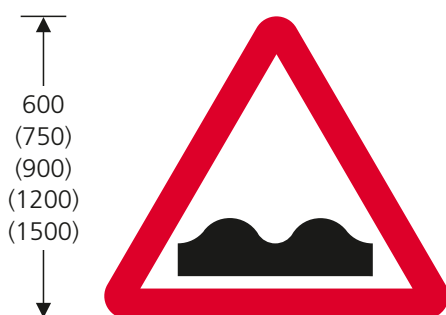
**555.1 Water course alongside road**

*May be used with diagram 570. The symbol may be reversed*

## 12 ROAD SURFACE

### UNEVEN ROAD

12.1 The uneven road sign, diagram 556, is used to warn of danger arising from longitudinal or transverse irregularities in the road surface which at the normal speed of traffic might seriously impair control of a vehicle. The use of this sign should generally be regarded as temporary, pending remedial work to the carriageway. It should be removed when the defect has been remedied. A plate to diagram 511 "REDUCE SPEED NOW" and also the distance plate to diagram 570 (see section 18) may be used with it. The uneven road sign should not be used at level crossings where the rail levels make the road uneven; para 21.13 describes the use of diagram 782 for this purpose.



556 Uneven road

*May be used with diagram 511 or 570*

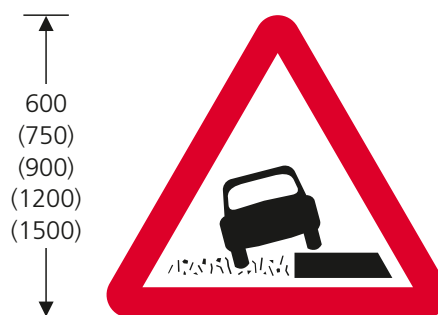
### SOFT VERGES

12.2 The soft verges signs, diagrams 556.1 and 556.2, should never be used simply to discourage parking. They are intended to deal with problems where driving on the verge can damage drains or might result in vehicles becoming stuck or damaging the verge. For lengths greater than two miles, the sign should be repeated at intervals of approximately one mile.

### SLIPPERY ROAD

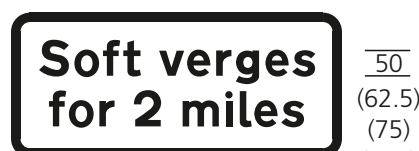
12.3 The slippery road sign, diagram 557, is intended for use where the danger of vehicles skidding is greater than normal. The distance plate to diagram 570 may be used with this sign (see section 18). The degree of danger cannot be precisely defined as this depends upon skid resistance value, speed of traffic and the degree of superelevation on bends. It is for the traffic authority

to judge whether overall conditions are sufficiently sub-standard that special warning is necessary. Detailed guidance can be found in HD 28 Skidding Resistance in Volume 7 of the Design Manual for Roads and Bridges (see para 1.3). Care must be taken not to over-use the sign, or its credibility will be undermined. Remedial works to improve the skidding resistance of the road surface or to improve drainage should be undertaken as soon as practicable and the signs removed on completion of the works.



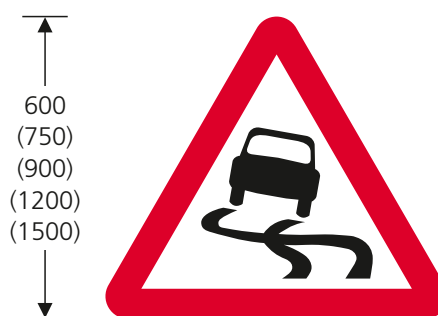
556.1 Soft verges

*May be used only in combination with diagram 556.2*



556.2 Soft verges for distance indicated

*May be used only in combination with diagram 556.1. The distance may be varied or omitted (see Appendix C)*



557 Slippery road

*May be used with diagram 570*

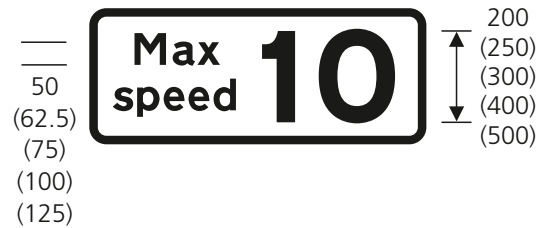
## LOOSE CHIPPINGS

**12.4** Loose chippings arising from surface dressing operations can pose a hazard either due to being thrown up into the path of oncoming vehicles or by causing vehicles to skid on the loose surface. While works are taking place, the sign to diagram 7009 should be used together with the supplementary plate to diagram 513.2, varied to indicate a recommended speed of 10 mph. On completion of the works, the sign may be retained for so long as the traffic authority considers it necessary to warn drivers (direction 36) in which case the supplementary plate should be replaced by the plates comprising sign diagram 7009.1. It is not permitted to vary the recommended speed on this sign. Further advice on signing during surface dressing operations can be found on the website of the Road Surface Treatments Association at [www.rsta-uk.org/publications.htm](http://www.rsta-uk.org/publications.htm).



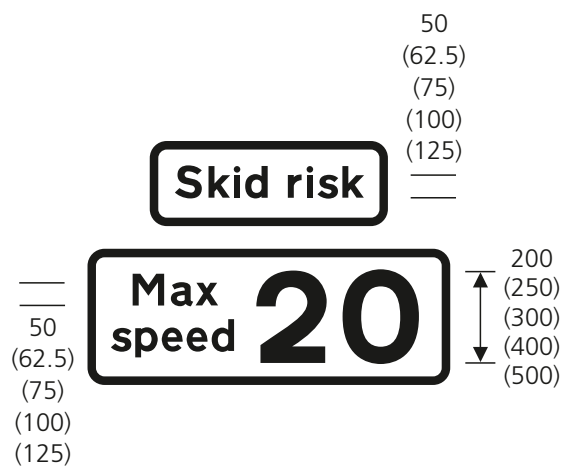
**7009** Loose chippings on road ahead

*May be used with diagram 513.2, 570, 572, 573 or 7009.1*



**513.2** Maximum speed advised

*May be used only in combination with diagram 7009 (or 512.1, 512.2, 513; see section 3). The speed may be varied*



**7009.1** Loose chippings on road ahead

*May be used only in combination with diagram 7009. The speed must not be varied*

## 13 ROAD HUMPS

13.1 Diagram 557.1 is used to warn of the presence of a road hump or a series of humps. It must be accompanied by one of the plates shown. The plates must not be used alone. However, no signs are required to warn of humps in a 20mph zone signed with traffic signs to diagram 674 (Highways (Road Humps) Regulations 1999). Road hump signs will usually benefit from the relaxation from the direct lighting requirement described in para 1.37.



557.1 Road hump or series of road humps

*May be used only in combination with diagram 557.2, 557.3 or 557.4, and with the marking to diagram 1062*

13.2 Figure 13-1 illustrates the range of signing that might be used where road humps are installed on adjacent roads within an area. Signs are needed at each entrance to the area, other than at short cul-de-sac with no humps and fewer than about 100 dwellings. If the humps are spaced more than 150 metres apart, each individual hump should be signed. Similar signing should be used where humps are installed on one road only.

13.3 Individual circumstances will determine whether signs for road humps should be provided on both sides of the road. Where a gateway is to be used as a speed-reducing feature in advance of humps, it is recommended that signs should be erected on both sides of the carriageway and incorporated into the gateway. Further advice on siting can be found in Appendix A.

13.4 Where several adjoining roads have humps, the distance on the sign plates should relate to the humps on the road on which the sign is erected. Separate signing for adjoining roads should not be necessary, provided the first hump in the adjoining road, whether it is the major or the minor one, is within 40 metres of the junction of the two roads.

13.5 As humps may be installed only on roads with speed control features, a 50 mm x-height is sufficient for the supplementary plate, 557.2. Diagrams 557.3 and 557.4 when incorporating an arrow indicate the presence of humps on side roads, and may themselves be used on roads where speeds are higher. A wider range of x-heights is therefore prescribed for these signs (see Annex B for details).

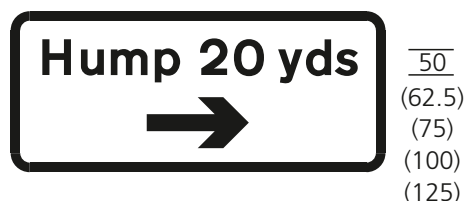
13.6 Signing of a humped Zebra or signalled crossing in a series of road humps will generally be necessary only if the spacing between it and adjacent humps is greater than 100 metres (see also para 9.13 for details of sign plates).



557.2 Road humps for the distance indicated



557.3 Road humps in the direction and for the distance indicated



557.4 Road hump in the direction and at the distance indicated

*These plates may be used only in combination with diagram 557.1. The distance may be varied (see Appendix C) and on diagrams 557.3 and 557.4 may be omitted. The legend on diagram 557.4 may be on two lines. On diagrams 557.3 and 557.4 the arrow may be reversed, or a second arrow pointing in the opposite direction may be added. The arrow on diagram 557.4 may be omitted; the appropriate x-height will then be 50 mm*

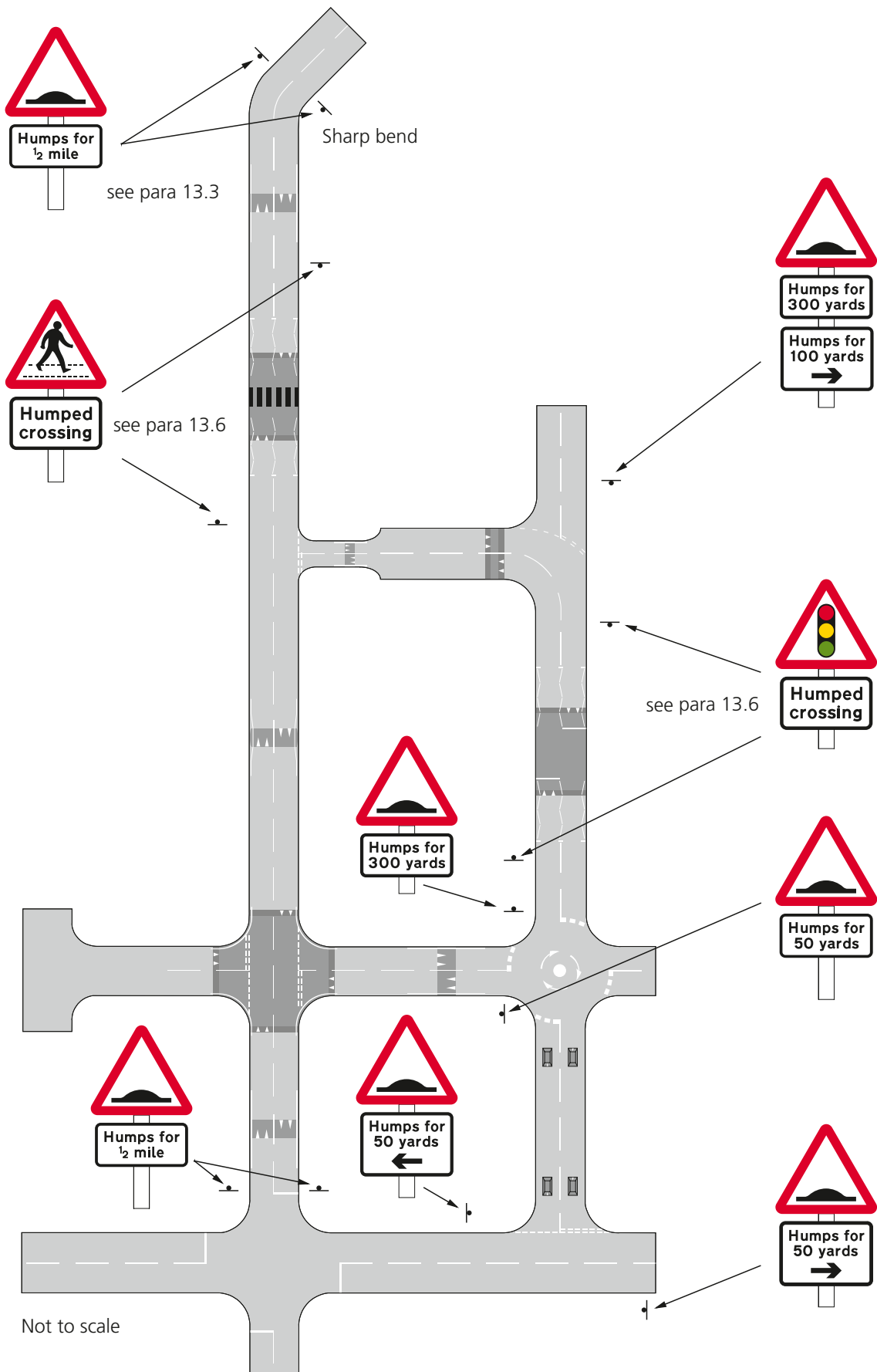


Figure 13-1



## 14 LOW-FLYING AIRCRAFT

**14.1** The low-flying aircraft sign, diagram 558, is for use on roads skirting or in the vicinity of airfields where road users are likely to be startled by low-flying aircraft or by sudden noise from aircraft. A plate to diagram 558.2 indicating "Gliders" should be added where appropriate. A plate to diagram 773 (see para 21.3) should be mounted below the sign if wig-wag signals are installed to control the movement of traffic during the take-off or landing of aircraft.

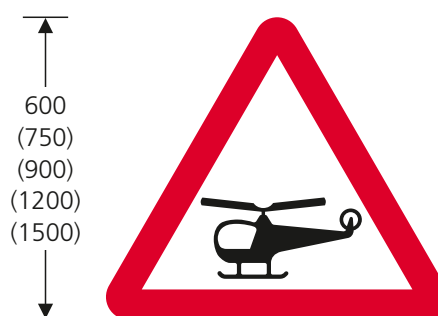
**14.2** The standard siting distances recommended in Appendix A are not likely to be appropriate for aircraft warning signs; an aeroplane might be virtually overhead before a driver sees the sign. It will therefore usually be more effective for this sign to be sited further in advance of the flight path, accompanied by a distance plate to diagram 570 (see section 18). However, in the case of wig-wag signals, signs to diagrams 558 and 773 should be sited at the standard distance from the stop line in addition to any general aircraft warning signs to diagram 558 used in advance. A distance may be added to diagram 558.2 where this is used; details can be found on the working drawing (see para 1.8).

**14.3** Where helicopters are likely to be encountered, the sign to diagram 558.1 may be used.



**558 Low-flying aircraft**

*May be used with diagram 558.2, 570 or 773*



**558.1 Low-flying helicopters**

*May be used with diagram 570*



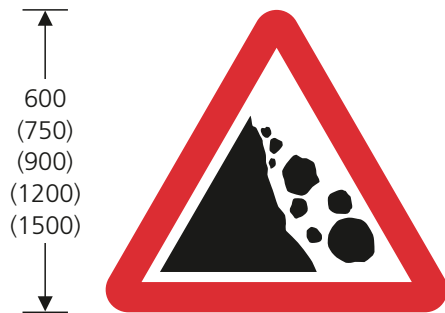
**558.2 Gliders**

*May be used only in combination with diagram 558.  
The legend "for" and a distance may be added*

## 15 FALLING OR FALLEN ROCKS

---

15.1 The falling or fallen rocks sign, diagram 559, should be used where there is a danger of rocks falling onto a road. A sign to diagram 570 indicating the length of road likely to be affected may be used with the sign. The symbol may be reversed when appropriate, but where rocks might fall from either side (e.g. in a gorge) the sign should be used as illustrated.



559 Risk of falling or fallen rocks

*May be used with diagram 570. The symbol is reversed when the hazard is on the right hand side of the road*

## 16 HAZARD MARKERS

16.1 Hazard markers (diagrams 560 and 561) may be circular or rectangular in shape, to the dimensions shown. They are prescribed in three colours. As viewed by the drivers of approaching vehicles these are:

- (i) red on the left hand edge of the carriageway
- (ii) white on the right hand edge of a single carriageway road
- (iii) amber on the right hand edge of a dual carriageway road adjacent to the central reservation, or a road carrying traffic in one direction only.

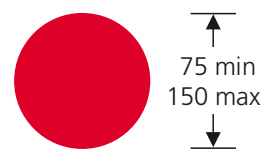
16.2 The top of the sign must be not less than 550 mm nor more than 1000 mm above the surface of the adjacent carriageway (direction 44). When mounted on a post specially provided for the purpose, that part of the post which extends above ground level should be not less than 100 mm wide and may be:

- (i) of any single colour, or
- (ii) coloured black and white in alternate horizontal bands, each band being not less than 225 mm nor more than 350 mm deep.

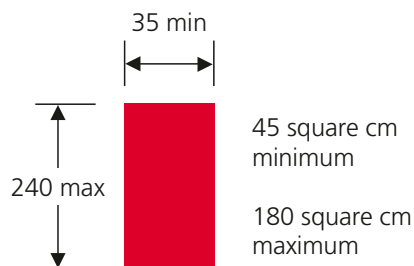
16.3 The black and white banded post enhances the conspicuity of the hazard marker. In rural areas or in areas where speeds are high, this type of post will generally be most suitable. In urban areas, or traffic-calmed zones, single-coloured posts may be appropriate.

16.4 The markers may be used to indicate the edge of the carriageway on embankments, mountain roads and other points where special danger exists. They may also be used, supplemented where appropriate with signs to diagrams 516 or 517 (see paras 4.1 to 4.4) to indicate a place where the carriageway suddenly narrows or to indicate obstructions such as a bridge parapet, abutment or building unusually near the carriageway edge. In these cases the markers may be fixed directly to the structure instead of to a separate post, but see also diagram 528.1 (para 7.2).

16.5 The signs must not be illuminated by means of internal or external lighting. They must be reflectorised by one of the means specified in regulation 21 (regulation 19 in the Traffic Signs Regulations (Northern Ireland) 1997).



560 Hazard at edge of carriageway



561 Alternative shape for 560

*The signs may be coloured red, white or amber and the surface of the sign to diagram 561 may be curved*

16.6 Care should be taken to ensure that hazard markers do not appear confusing at night. This may occur for example if headlights (with raised or dipped beams) are reflected from markers delineating more than one bend. It is recommended that, following installation, they are checked at night from a moving vehicle.

16.7 The use of hazard markers on safety fences or barriers is not recommended on high-speed roads. Safety fences do not consistently follow the line of the road edge; mounting reflectors on them is likely to mislead drivers as to the true position of the verge. The recommended method of delineating the road edge is to use edge of carriageway markings (incorporating raised ribs if appropriate) together with road studs. It may sometimes be appropriate to use markers on safety fences on sinuous mountain roads over short lengths, or at sharp bends, where separate posts may be inconvenient. When used in this way, the markers must still conform to the Regulations and to the requirements specified in direction 44 with respect to colour, size, shape and mounting height. Consideration should also be given to the potential consequences of the fence being struck by a vehicle. If the markers are of heavy construction, they could themselves be hazardous.

## 17 OTHER DANGER

17.1 Although prescribed mainly for temporary use to warn of transient or occasional hazards such as "Dust cloud" or "Census", diagram 562 is also used for certain permanent features not easily represented symbolically, e.g. "Hidden dip".

17.2 The sign conveys no specific message on its own; it must always be accompanied by one of the supplementary plates prescribed as diagram 563, 563.1, or 7022 when used at temporary traffic signal installations (see Chapter 8). Reference should always be made to the working drawings (see para 1.8) to determine the correct layout of the different legends.

17.3 When the legend on the sign to diagram 563 indicates the temporary hazards "Accident", "Census", "Dust cloud", "Fallen tree", "Frost damage", "Overhead cable repairs", "Runners in road", "Smoke" or "Walkers in road", the sign may



562 Other danger ahead

May be used only in combination with diagram 563, 563.1 or 7022 "JOINING TRAFFIC NOT SIGNAL CONTROLLED"



563 Nature of other danger

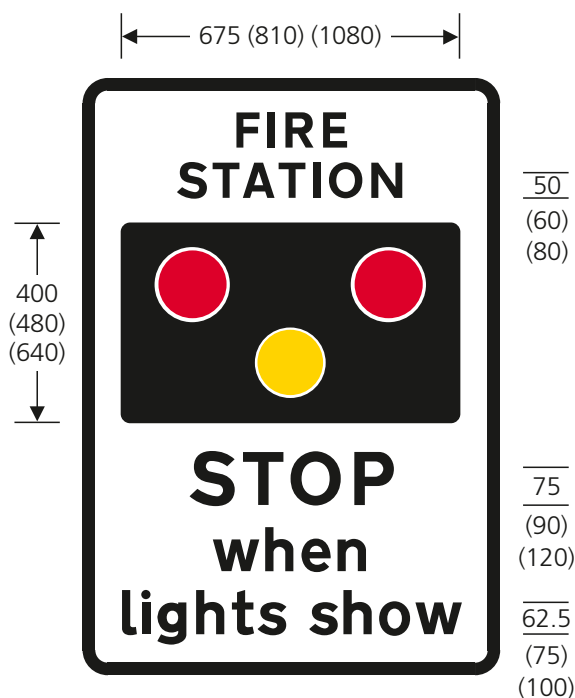
May be used only in combination with diagram 562, or when varied to "Road liable to flooding" with diagram 554. "Accident" may be varied to "Ambulance station", "Blasting", "Blind summit", "Census", "Dust cloud", "Fallen tree", "Fire station", "Frost damage", "Hidden dip", "Overhead cable repairs", "Pedestrians crossing", "Runners in road", "Smoke" or "Walkers in road".  
A distance, an arrow or both may be added

be retained only for so long as the hazard indicated continues to exist or is expected to recur in the near future (direction 39(3)).

17.4 When diagram 563 is varied to "Pedestrians crossing", it may be used where pedestrians frequently cross high-speed roads, although no formal provision is made for them, and sited at a distance appropriate to the 85th percentile speed (see Appendix A). Such locations may be where new by-passes intersect established pedestrian routes. As the crossing point is unlikely to be apparent to drivers, a distance should normally be added, in accordance with the working drawing (see para 1.8). The sign must not be used where a formal crossing, such as a Zebra or Pelican crossing, is provided.

### WIG-WAG SIGNALS

17.5 The sign to diagram 563.1, in combination with diagram 562, may be used only where wig-wag signals to diagram 3014 are installed in the vicinity of premises used regularly by fire, police or ambulance service vehicles.



563.1 Stop when lights show

May be used only in combination with diagram 562. "FIRE" may be varied to "AMBULANCE", "POLICE", "FIRE AND AMBULANCE", "FIRE AND POLICE", "POLICE AND AMBULANCE" or "FIRE, POLICE AND AMBULANCE". A distance, an arrow or both may be added

## 18 DISTANCE PLATES

**18.1** These plates are prescribed for use with many of the warning signs described in this chapter (see direction 21, items 35 to 37). However, many supplementary plates may incorporate distances, obviating the need for separate distance plates. These are diagrams 518, 519, 530.1, 543.1, 546, 547.1, 547.2, 547.4, 547.7, 547.8, 563, 563.1, 773 and 950.1. Diagrams 518 and 519 may also include the word "for" before the distance, and "for" and a distance may be added to diagrams 553.2, 554.3 and 558.2. The working drawings (see para 1.8) show the correct layouts.



(50)  
 $\frac{62.5}{}$   
 (75)  
 (100)  
 (125)  
 (150)  
 (200)

570 Distance over which hazard extends



(50)  
 $\frac{62.5}{}$   
 (75)  
 (100)  
 (125)  
 (150)  
 (200)

572 Distance to hazard



(50)  
 $\frac{62.5}{}$   
 (75)  
 (100)  
 (125)  
 (150)  
 (200)

573 Distance and direction to hazard

*The indication of distance on these signs may be varied (see Appendix C). On diagram 573, the distance may be omitted. The direction of the arrow may be reversed*

**18.2** Diagram 570 is used to indicate the distance over which a hazard extends. Generally, if this is for more than two miles, the warning sign should be repeated at suitable intervals with the plate indicating the remaining distance to the end of the hazard. However, account should be taken of visual obstructions en-route e.g. a rock outcrop might hide sheep wandering onto the road, necessitating a sign at that point.

**18.3** On motorways or other roads with grade separated junctions where the hazard might extend over a long distance, (e.g. wild animals) the warning sign with a plate to diagram 570 should be repeated after every access slip road, or, if this distance would be excessive, at intervals of approximately five miles. Each plate should show the distance remaining to the end of the hazard.

**18.4** Diagram 572 indicates the distance ahead to a hazard. The caption below each diagram illustrated in this chapter specifies if a distance plate may be used (but see para 18.1). Where such a sign is sited at a distance from the hazard significantly different to that recommended in Appendix A, it should normally be supplemented with a distance plate (see also para 1.20).

**18.5** Diagram 573 is placed in advance of a junction, indicating the distance along the road from that junction to the hazard. The distance is measured from the junction and not from the sign. The sign may be sited on a minor road approaching a junction if the hazard is on the major road. The direction of the arrow may be reversed.

**18.6** The distance shown on all three plates may be varied with

- (i) distances over 3 miles being expressed in miles to the nearest mile;
- (ii) distances of  $\frac{1}{2}$  mile or more but less than 3 miles being expressed to the  $\frac{1}{4}$  mile; and
- (iii) distances of less than  $\frac{1}{2}$  mile being expressed in yards to the nearest 10 yards.

In no circumstances may metric distances be used.

## 19 MISCELLANEOUS HAZARDS

### ANIMAL DISEASE

19.1 The sign to diagram 574 (see para 1.19 for sizes) is for use in connection with an outbreak of an animal disease. The appropriate name of the disease should be shown on the sign. It should be erected on



—  
40 min  
200 max

574 Area infected by animal disease

*"RABIES" may be omitted or varied to any appropriate animal disease. "AHEAD" may be omitted or varied to "ENDS" or to a horizontal arrow pointing to the left or to the right*



(50)  
62.5  
(75)  
(100)  
(125)  
(150)

575 Large vehicles in middle of road

*May be used only in combination with diagram 512, 512.1, 512.2, 513, 516, 517, 528 or 529.1*

↑  
600  
(750)  
(900)  
(1200)  
(1500)  
↓



581 Side winds

*May be used with diagram 570*

roads at the boundaries of infected areas designated under the Animal Health Act 1981. During the 2001 foot and mouth outbreak, many areas were badly signed. To assist in proper control of the disease, traffic authorities should ensure that the prescribed warning signs are used. The signs must be removed when the area has been cleared of the disease.

19.2 Diagram 574 has been designed to allow space for the variants for different diseases to be applied by sliding appropriate plates into runners fixed to the sign (refer to the working drawing, see para 1.8). This should facilitate the making up of appropriate signs when an outbreak of disease occurs. Only one or two basic sign plates need to be stocked, together with a plate for each disease likely to occur.

### ONCOMING VEHICLES

19.3 Diagram 575 is used where some physical restriction requires large vehicles to be driven in the middle of the road over a short distance. It is not intended to be used where the general width of a road is such that a large vehicle would be forced to straddle the centre line over a long distance. It may be used in combination with the "bend" signs to diagrams 512, 512.1, 512.2 and 513 (see paras 3.1 to 3.8) and the "road narrows" signs to diagrams 516 and 517 (see paras 4.1 to 4.3). It might also sometimes be appropriate to use it with the "hump bridge" sign (diagram 528) or the "tunnel" sign (diagram 529.1). Diagram 531.2 should be used at arch bridges (see paras 7.21 to 7.24). Where double white lines (diagram 1013.1) are used, they should be interrupted so that no vehicle is forced to cross them.

### SIDE WINDS

19.4 The "side winds" sign to diagram 581 is used where vehicles are suddenly exposed to risk from strong winds. Such locations may include exposed bridges or places where vehicles emerge from cuttings in areas which are particularly prone to high winds. Drivers must anticipate some adverse effects caused by wind and in order to maintain the effectiveness of this sign, it should not be over-used.

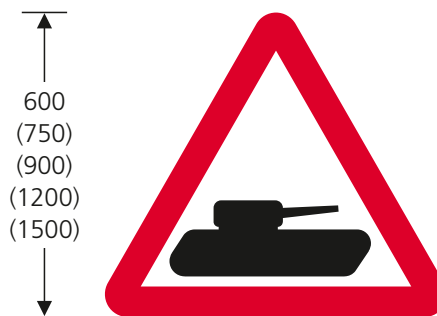
19.5 The sign may be used with a distance plate to diagram 570 where an unusual hazard exists over a longer length, e.g. on a viaduct or high embankment. However, it should not normally be used on the open road, where drivers must expect gusts of wind.

## 20 SLOW-MOVING VEHICLES

### MILITARY VEHICLES

20.1 The sign to diagram 582 may be used at locations where military vehicles are expected either to cross the road ahead or to be moving at low speed along the road. If the vehicles have regular entry and exit points along the road, distance plates may be appropriate (see section 18).

20.2 The sign is not restricted to warning of tanks; it may be used for any military vehicles which are either larger than might normally be expected along that type of road, or travel at reduced speed.



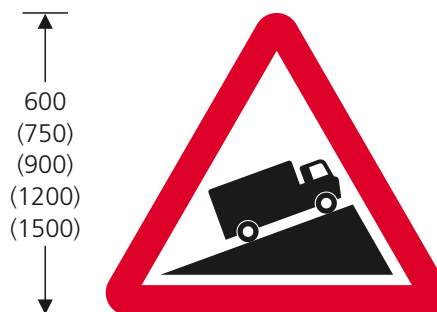
582 Slow-moving military vehicles

*May be used with diagram 570*

### SLOW LORRIES

20.3 The slow-moving vehicles signs, diagrams 583 and 583.1, are intended for use on roads where the gradient is such as to have an adverse effect on the speed of heavy commercial vehicles, thereby causing a potential hazard to other vehicles in the same lane. This is not simply a question of congestion. The problem can occur even when there is more than one lane. At times of light traffic flow, a vehicle being driven in the left hand lane at 70 mph might close unexpectedly rapidly on a slow-moving lorry, or on a queue of vehicles waiting to pass it.

20.4 The criteria for using these signs will differ from the criteria for normal steep hill signs because they are aimed at drivers following the slow vehicle and not at the driver of the slow vehicle itself. In addition to the gradient of the hill, consideration should be given to the length of the hill and the differential speed of heavy and other traffic. They are most likely to be of use on motorways and high-speed dual carriageway roads with substandard gradients. The sign should be used for uphill traffic only; the "steep hill" signs in section 6 should be used in the downhill direction.



583 Slow-moving vehicles on incline

*May be used only in combination with diagram 583.1*



583.1 Distance over which slow-moving vehicles hazard extends

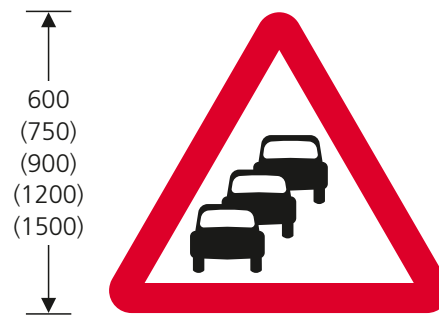
*May be used only in combination with diagram 583.  
The distance may be varied (see Appendix C)*

## QUEUES LIKELY

**20.5** Drivers should expect to meet queues on the approaches to roundabouts or traffic signals, where adequate advance warning can usually be given using signs to diagram 510 (see paras 2.13 to 2.18) or 543 (see section 8) as appropriate. The "Queues likely" signs, diagrams 584 and 584.1, are intended for use where drivers might unexpectedly come across a queue, e.g. around a bend or over the brow of a hill. These signs should be used only where there is a persistent problem, causing a significant hazard, despite the presence of the standard warning signs and are not appropriate as a general warning of congestion. They should be sited sufficiently far in advance of the obstruction to the sight line to enable drivers to stop in time. Distance plates must not be used.

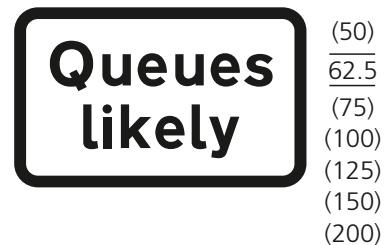
**20.6** Where the queue is likely to be in a road that leads from a junction ahead, the "Queues likely" plate may incorporate an arrow pointing to the left or to the right as appropriate. Details are shown on the working drawing (see para 1.8).

**20.7** The sign may also be used on motorways or other high-speed dual carriageway roads with grade separated junctions where queues on an exit slip road regularly extend back onto the main carriageway. Where queues on the slip road effectively shorten the deceleration length available, but do not usually extend onto the main through carriageway, the variant "Queues likely on slip road" should be used. Care should be taken to ensure that the assembly does not obstruct the driver's view of existing signs.



**584** Traffic queues likely

May be used only in combination with diagram 584.1



**584.1** Queues likely on road ahead

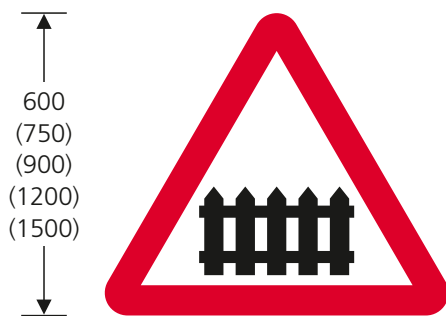
May be used only in combination with diagram 584. An arrow may be added to the sign. "Queues likely" may be varied to "Queues likely on slip road"



## 21 LEVEL CROSSINGS

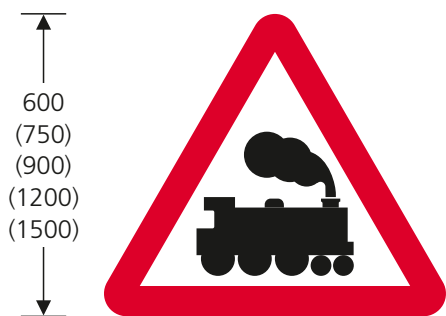
**21.1** This section gives a brief description of the prescribed traffic signs used at level crossings and tramway crossings. For further guidance, reference should be made to the Office of Rail Regulation's (ORR) publication "Railway Safety Publication 7, Level Crossings: A guide for managers, designers and operators" published on the ORR website. See also section 3 in Chapter 3.

**21.2** Diagram 770 is used on the approach to a railway level crossing which is equipped with gates or barriers. This sign is also used at a tramway crossing if barriers are provided. Diagram 771 is used in advance of open railway level crossings which have neither gates nor barriers. Diagram 772 is used in advance of open tramway crossings which have neither gates nor barriers. These signs should normally be sited at a distance from the crossing related to the 85th percentile speed of approaching vehicles, in accordance with Appendix A. See also paras 21.17 and 21.18 for guidance on the use of countdown markers and signing for queuing traffic.



**770** Level crossing with gate or barrier

*May be used with diagram 572, 573 or 773*

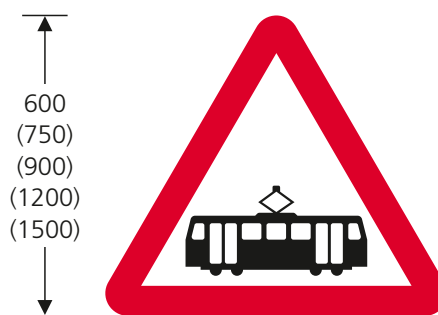


**771** Railway level crossing without gate or barrier

*May be used with diagram 572, 573 or 773*

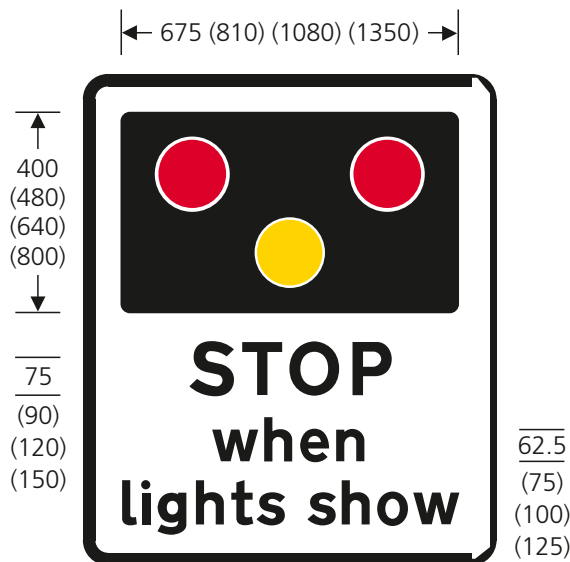
**21.3** Diagram 773 should be used in advance of wig-wag signals to diagram 3014 at both railway and tramway level crossings. An arrow may be added to the sign pointing either to the left or to the right. An indication of distance may be added. The sign may be used only in combination with one of the warning signs described above, or with diagram 529, 529.1 or 558 where wig-wag signals are used at an opening bridge, a tunnel or an airfield (see paras 7.3, 7.4, 14.1 and 14.2).

**21.4** Diagram 774 is used to indicate the location of a level crossing which has no gate or barrier. The same sign is used regardless of the number of tracks and at tramway as well as railway crossings.



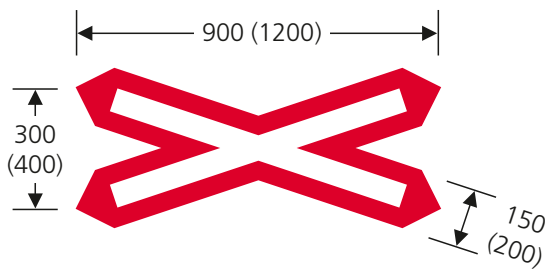
**772** Tramcar crossing without barriers

*May be used with diagram 572, 573 or 773*



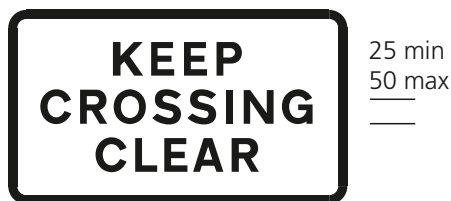
**773** Stop at level crossing or tramcar crossing when lights show

*May be used only in combination with diagram 529, 529.1, 558, 770, 771 or 772. A distance, an arrow or both may be added*



**774** Location of railway or tramway crossing without gate or barrier

*May be used with diagram 602 when used with 778 or 778.1, or with signals to diagram 3014*



**775** Area to be kept clear at railway or tramway level crossing

*May be used with signals to diagram 3014*



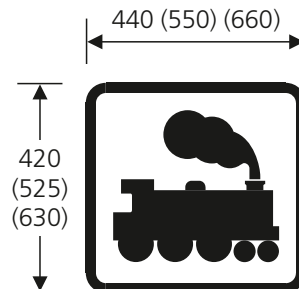
**776** Warning of another train or tramcar approaching the crossing

*May be used with signals to diagram 3014. "TRAIN" may be varied to "TRAM"*



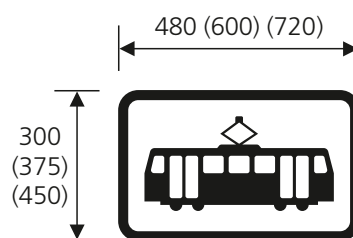
**777** Another train or tram passing

*May be used with signals to diagram 3014. "TRAIN" may be varied to "TRAM"*



**778** Open railway level crossing without light signals

*May be used only in combination with diagram 602*



**778.1** Open tramway crossing without light signals

*May be used only in combination with diagram 602*

**21.5** Diagram 775 is used at all automatic and open crossings. It should not be used at crossings with manually controlled barriers, nor at those which are user operated, unless specifically authorised in the Level Crossing Order. At automatic crossings, it should be placed on each primary and duplicate primary signal post. At open crossings, it should be mounted on both sides of the road, on or near the post carrying the sign to diagram 774.

**21.6** Diagram 776 is used at locally-monitored automatic open crossings on double-track lines, where two trains can arrive in quick succession. The sign should be sited on the left hand side of the road.

**21.7** Diagram 777 is used at all automatic crossings on double-track lines. The sign should be placed on or near each duplicate primary road traffic signal.

**21.8** Diagrams 778 and 778.1 are used with the GIVE WAY sign to diagram 602 and not with signals to 3014. Special authorisation (see para 1.5) is required to use diagram 778.1 with the STOP sign to diagram 601.1.

**POWER CABLES**

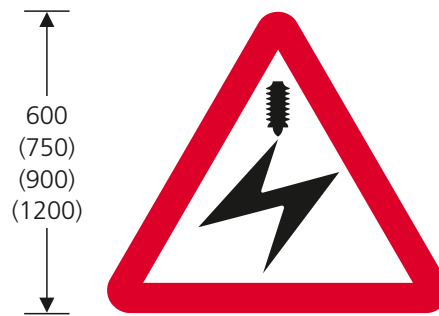
**21.9** Diagram 779 warns of a place where a road passes under an electrified overhead power cable. It must always be accompanied by a plate indicating the safe maximum height vehicle that can pass below the cable. These signs are normally associated with overhead electric railway or tramway cables and should be used at all such crossings. Because of the high voltage of certain cables, it is very important to ensure that adequate warning is given even where cable heights are greater than 16'-6" (5.03 m).

**21.10** Supplementary plates 780A, 780.1A and 780.2A indicate this maximum safe height. The dimension may be varied and should show a height which is at least 2'-0" (600 mm) below the height of the overhead conductor for 25kV systems and 1'-6" (460 mm) for systems on lower voltages. At a crossing where the safe height is below 16'-6" (5.03 m), the height shown on the signs should be at least 1'-9" (530 mm) or 1'-3" (380 mm) respectively below the conductor and a load gauge to diagram 781 erected at the safe height. In calculating the safe height, allowance should be made for the effect of the vertical profile of the carriageway on a road vehicle and its load. While the Regulations permit the omission of the height indication in metric units, this is inadvisable. Table 21-1 indicates the heights to be shown on the signs for different cable heights.

**LOAD GAUGE**

**21.11** The load gauge shown in diagram 781 gives an audible warning when the safe height beneath an overhead power cable is exceeded. It should always be used where the safe height is less than 16'-6" (5.03 m); see also para 21.12. A safe height less than 16'-6" is likely to be encountered only at private crossings. At such locations the gauge should be effective as speeds are low and users familiar with the layout. The gauge is intended for use with power cables and not at low bridges over public highways, where speeds are likely to be higher and drivers less able to respond to the sound of the bells in time, or even to hear them at all from inside closed cabs.

**21.12** The load gauge must be mounted on two posts coloured black and white in alternate horizontal bands, each band being not less than 250 mm nor more than 335 mm deep (direction 43). Diagram 779 with supplementary plate 780.2A should be used when a load gauge is installed.



**779 Electrified overhead cable**

*May be used only in combination with diagram 780A, 780.1A or 780.2A*



**780A Safe height beneath cable**

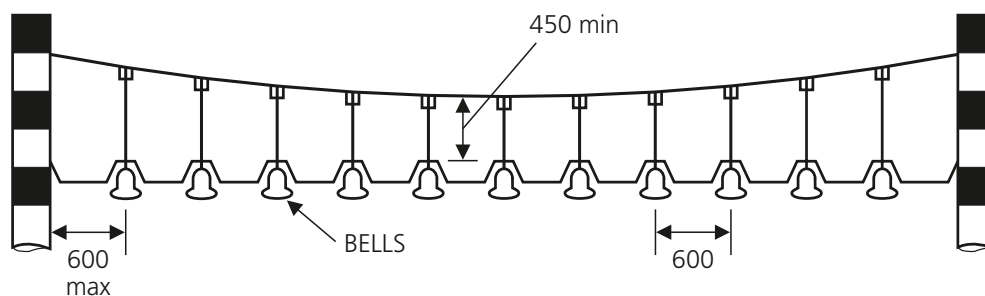


**780.1A Safe height beneath cable in direction and at distance indicated**



**780.2A Load gauge and safe height beneath cable**

*These plates may be used only in combination with diagram 779. The height may be varied. The height in metric units may be omitted. In diagram 780.1A the arrow may be reversed or omitted, and the distance may be varied or omitted*



781 Load gauge giving audible warning below electrified overhead cables

The number and colour of the bells may be varied

Table 21-1

| Lowest hot weather height of contact wires above road |        | Height of gauge (diagram 781) and height to be shown on supplementary plate (diagrams 780A, 780.1A and 780.2A) for different overhead line voltages |        |                       |        | Signs to be used                                     |
|---|--------|---|--------|-----------------------|--------|--|
|   |        | 25000 volts   |        | Less than 25000 volts |        |  |
| Imperial  | Metric | Imperial  | Metric | Imperial              | Metric |  |
| 18'-9"  | 5.71 m | 16'-9"  | 5.1 m  | 17'-3"                | 5.2 m  | Diagram 779 with 780A or 780.1A                      |
| 18'-6"  | 5.64 m | 16'-6"  | 5.0 m  | 17'-0"                | 5.1 m  |  |
| 18'-3"  | 5.56 m | -   | -      | 16'-9"                | 5.1 m  |  |
| 18'-0"  | 5.49 m | -   | -      | 16'-6"                | 5.0 m  |  |
| 18'-3"  | 5.56 m | 16'-6"  | 5.0 m  | -                     | -      | Load gauge (diagram 781) and diagram 779 with 780.2A |
| 18'-0"  | 5.49 m | 16'-3"  | 4.9 m  | -                     | -      |  |
| 17'-9"  | 5.41 m | 16'-0"  | 4.8 m  | 16'-6"                | 5.0 m  |  |
| 17'-6"  | 5.33 m | 15'-9"  | 4.8 m  | 16'-3"                | 4.9 m  |  |
| 17'-3"  | 5.26 m | 15'-6"  | 4.7 m  | 16'-0"                | 4.8 m  |  |
| 17'-0"  | 5.18 m | 15'-3"  | 4.6 m  | 15'-9"                | 4.8 m  |  |
| 16'-9"  | 5.10 m | 15'-0"  | 4.5 m  | 15'-6"                | 4.7 m  |  |
| 16'-6"  | 5.03 m | 14'-9"  | 4.5 m  | 15'-3"                | 4.6 m  |  |

**LONG VEHICLES**

21.13 Diagram 782 is used at crossings where there is a risk of long or low vehicles grounding and causing an obstruction which might not be cleared before the next train arrives at the crossing. It is necessary to consider both the approach profile and the relative levels of the running rails. For guidance on the use of this sign with hump bridges see para 7.1.

21.14 Diagrams 783, 784.1 and 785.1 instruct drivers of long, low, large or slow vehicles to phone to obtain permission before crossing the railway. The smallest size of the sign to diagram 785.1 (25 mm x-height) is intended to be read only by a driver having alighted. A larger size will be required if it is necessary for the sign to be read from a moving vehicle. As non-compliance with the sign to diagram 784.1 could result in an accident or expose a driver to prosecution, it is essential that this group of signs is appropriately sized and properly maintained.



782 Risk of grounding

May be used with diagram 528, 572, 573, 783, 785.1 or 786



50 min  
100 max

783 Drivers of long low vehicles to telephone before crossing

"LONG LOW" may be varied to "LARGE OR SLOW".  
May be used with diagram 601.1, 782, 785.1, 786, 787 or 788



45 min  
75 max

30 min  
50 max

784.1 Drivers of large or slow vehicles to telephone before crossing

May be used with diagram 786, 787 or 788.  
"must phone" may be varied to "must use SOS phone"



(25)  
50  
(62.5)  
(75)  
(100)  
(125)

785.1 Name of level crossing and telephone number of railway or tramway

May be used with diagram 782 or 783.  
The telephone number may be varied and "RAILWAY" may be varied to "TRAM Co."

21.15 Diagram 786 indicates the positions at which a vehicle should wait while the driver telephones before or after crossing the line. A marking to diagram 1028.3 (with no accompanying legend) may be used with the sign (direction 25(1)).



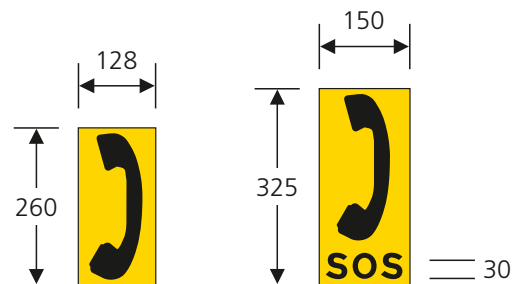
786 Parking place for driver to telephone

May be used with diagram 782, 783, 784.1, 787, 788 or 1028.3. "AT CROSSING" may be omitted. "AND USE PHONE" may be varied to "AND USE SOS PHONE" or "& USE SOS PHONE". The latter should be used only when plating an existing sign (see working drawing P 786)

21.16 Diagrams 787 and 788 are used to indicate the location of the telephone. Diagram 788 is used only where this is not readily apparent.

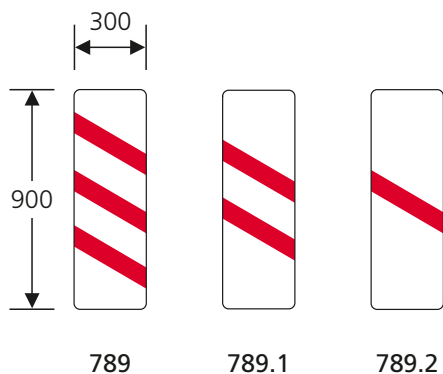
**COUNTDOWN MARKERS**

21.17 Countdown markers to diagrams 789, 789.1 and 789.2 may be used to emphasise the approach to a crossing. They are intended to divide into equal lengths the distance between the first marker, with three bars, and the crossing. The first marker should be co-located with the warning sign to diagram 770, 771 or 772 (see para 21.2). Unlike the countdown markers on the approach to a junction, the bars do not represent intervals of 100 yards, as the warning sign will usually be less than 300 yards from the crossing. If the signs are duplicated on the off side of the road, for greater emphasis or to improve visibility, the slope of the bars is reversed.



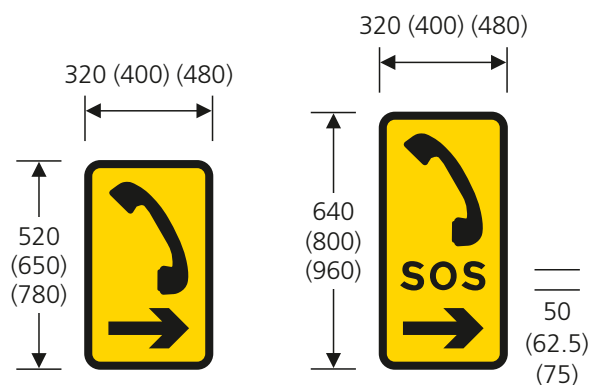
787 Site of telephone (Alternative types)

21.18 Where queues sometimes extend upstream of the crossing warning signs, especially if the end of the queue might be hidden by a bend, queue warning signs might be necessary (see para 20.5).



Countdown markers to level crossing

The symbols are reversed when the signs are mounted on the off side



788 Direction to telephone (Alternative types)

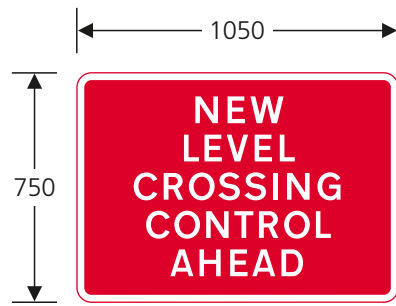
The direction of the arrow may be reversed

**NEW CROSSINGS**

21.19 Diagram 790 is used following alteration of the method of control of a level crossing. In the case of a new installation, "CONTROL" should be omitted. The sign must be removed within three months of the date of completion of the works (direction 37(1)).

**SIZES OF LEVEL CROSSING SIGNS**

21.20 Guidance on the appropriate sizes for triangular warning signs and supplementary plates can be found in Appendices A and B respectively. Diagrams 774, 775, 777, 783 to 786 and 788 are prescribed in several sizes, the smallest being appropriate where approach speeds do not exceed 30 mph, and the largest where the national speed limit applies. For intermediate approach speeds, sizes should be proportioned accordingly, using the nearest prescribed size.

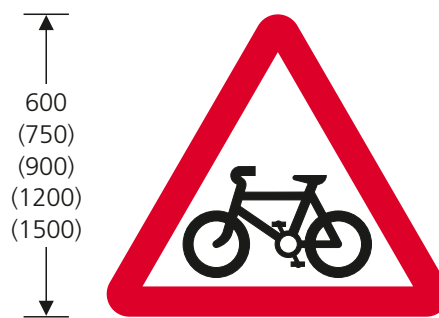


790 New method of control at level crossing

## 22 CYCLING

22.1 Diagram 950 may be used to warn traffic of a place where a cycle route crosses or joins a road and is not controlled by traffic signals. Where cyclists emerge only from the left, the symbol should be reversed. If cycles cross the road, a plate to diagram 950.1, varied to "Cycles crossing" may be used; a distance and if appropriate an arrow may be added (i.e. if the cycle crossing is in a side road or another road). Details can be found on the working drawing (see para 1.8). Where cycles join the road but do not cross it, a distance plate to diagram 572 (or 573 if the cycle route is in a side road) may be used. Where the junction is controlled by traffic signals, no warning sign is normally needed. If visibility of the signals is restricted, the appropriate sign is diagram 543 (see section 8).

22.2 Diagram 950.1 may be displayed when a children's cycle testing or training session is in progress. It must be used with diagram 950 and be removed when the session is completed. When a cycle rally or similar event is in progress, the variant "Cycle event" may be used. An indication of the distance to the hazard may be included, and an arrow pointing to the left or to the right if the hazard is in another road.



950 Cycle route

*May be used with diagram 572, 573 or 950.1.  
The symbol may be reversed*



950.1 Training or testing  
of child cyclists

*May be used only in combination with diagram 950.  
"tests" may be varied to "training". "Child cycle tests"  
may be varied to "Cycles crossing" or to "Cycle event".  
A distance, an arrow or both may be added*



## 23 REFUGE BEACON

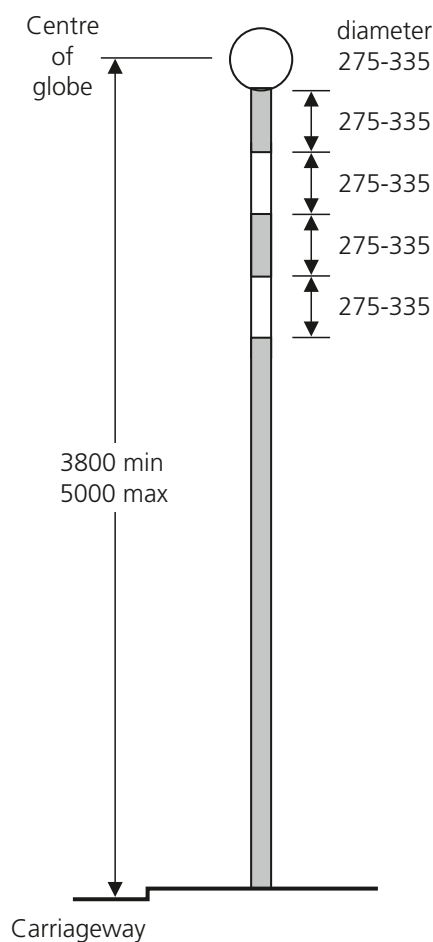
**23.1** The purpose of the beacon is to indicate the presence of a refuge which might be obscured by other traffic, the brow of a hill or a bend. It is not normally necessary on refuges which carry lighting columns or traffic light signals.

**23.2** The beacon consists of an illuminated spherical globe conforming to the following requirements prescribed in regulation 57 (regulation 46 in the Northern Ireland Regulations, where the dimensions are slightly different):

- (i) the globe shall be white;
- (ii) it shall have a diameter of not less than 275 nor more than 335 mm;
- (iii) the height of the centre of the globe above the surface of the carriageway in the immediate vicinity shall be not less than 3800 mm nor more than 5000 mm.

**23.3** The beacon post should, except as provided in para 23.4, be coloured grey or black, unless it is of aluminium, concrete or galvanised metal construction, in which case it may retain its natural colour (see direction 45). Two white bands must be added, each band being between 275 and 335 mm in depth, separated by a gap of the same dimensions. The top white band should be between 275 and 335 mm below the white globe. The two white bands may be internally illuminated. Signs to diagram 610 to indicate which side drivers should pass may be added at a higher level than those mounted in the bollards.

**23.4** When a beacon is placed on a street refuge or central reservation at a Zebra crossing and yellow globes are also attached to the same post, the post from ground level up to the point where the yellow globes are attached must be coloured in alternate black and white horizontal bands. The lowest band must be black and be between 275 and 1000 mm deep, with the other bands being not less than 275 nor more than 335 mm deep. Above the point where the yellow globes are attached, the post should be coloured in accordance with para 23.3.



**Figure 23-1**  
Refuge beacon

## SIZES OF WARNING SIGNS AND SITING DETAILS

| 1   | 2  | 3  | 4   |
|---|--|--|---|
| 85th percentile speed of private cars (mph) | Height of triangular warning signs <sup>3</sup> (mm) | Minimum clear visibility distance <sup>4</sup> (m) | Distance of sign from hazard <sup>5</sup> (m) |
| Up to 20                                    | 600  | 45   | 45  |
| 21 to 30                                    | 600  | 60   | 45  |
| 31 to 40                                    | 750 (600) <sup>1</sup>                               | 60   | 45-110  |
| 41 to 50                                    | 900 (750) <sup>1</sup>                               | 75   | 110-180                                       |
| 51 to 60                                    | 1200 (900) <sup>1</sup>                              | 90   | 180-245                                       |
| Over 60                                     | 1200 (1500) <sup>2</sup>                             | 105 (120) <sup>2</sup>                             | 245-305 <sup>2</sup>                          |

### NOTES

1. The smaller bracketed sizes shown in column 2 should be used only where special amenity considerations or physical constraints apply (see para 1.14). The minimum clear visibility distance specified in column 3 should not be reduced.

2. The 1500 mm size shown in column 2, and the largest visibility and siting distances in columns 3 and 4, should normally be used where the speed limit is 70 mph on dual three-lane or four-lane motorways or all-purpose roads with hard shoulders. In other circumstances the 1200 mm size should normally be used, with the 105 m minimum clear visibility distance (see paras 1.22 and 1.23) shown in column 3 and the siting distance (see paras 1.20 and 1.21) shown in column 4 (adjusted in accordance with Note 5 below). However, road safety considerations may require a larger size. The Regulations prescribe a 1500 mm size for most warning signs, which may be used on roads other than those described above.

3. The table below shows, in millimetres, the appropriate heights of the triangular warning signs and the diameters of regulatory signs that indicate the headroom of a bridge or other structure. For signs on the approach, the minimum clear visibility distance and the distance from the hazard shall be in accordance with the above table for all warning signs. The signs to diagram 530 and 530A when placed on the approach to a hazard are more likely to indicate an overhanging building or structure where the maximum size is 900 mm and 1200 mm respectively (see Appendix B) rather than to indicate a low bridge (see section 7).

| Diagram number and sign location | 85th percentile speed of private cars (mph) |          |          |         |
|----------------------------------|---|----------|----------|---------|
|                                  | Up to 30                                    | 31 to 40 | 41 to 50 | Over 50 |
| 530 mounted on structure         | 750   | 900      | 1200     | 1500    |
| 530 on approach                  | 600   | 750      | 900      | 1200    |
| 530A mounted on structure        | 900   | 1200     | 1500     | 1800    |
| 530A on approach                 | 750   | 900      | 1200     | 1500    |
| 531.1 on approach                | 750   | 900      | 1200     | 1500    |
| 532.2                            | 750   | 900      | 1200     | 1500    |
| 532.2A                           | 900   | 1200     | 1500     | 1800    |
| 532.3 (centre of arch)           | 750   | 900      | 1200     | 1500    |
| 532.3 (side of arch)             | 600   | 750      | 900      | 1200    |
| 532.3A (centre of arch)          | 900   | 1200     | 1500     | 1800    |
| 532.3A (side of arch)            | 750   | 900      | 1200     | 1500    |
| 629.2 mounted on structure       | 600   | 750      | 900      | 1200    |
| 629.2 on approach                | 600   | 750      | 900      | 1200    |
| 629.2A mounted on structure      | 750   | 900      | 1200     | 1500    |
| 629.2A on approach               | 750   | 900      | 1200     | 1500    |

4. For further guidance on clear visibility distance, see paras 1.22 and 1.23. Siting also needs to take account of the location of other signs (e.g. advance direction signs) to ensure that one sign does not obstruct the sight line to another. Provision of a new sign might sometimes require the relocation of an existing one.

5. For further guidance on sign siting, see paras 1.20 and 1.21. Where a range is quoted for siting distance in column 4, progressively larger figures should be used for 85th percentile speeds towards the higher end of the speed range, to compensate for the greater braking distance. Braking distance will also be affected by gradients, and siting distances may need to be increased on steep hills, e.g. an increase of 50% might be made for a 10% descent. Special considerations apply to the signs listed below:

- (i) When used on single carriageway roads:  
Diagram 517 "Road narrows" at the end of a climbing lane - see para 4.3  
Diagram 563, when indicating "Blind summit" or "Hidden dip", might need to be placed further from the hazard than shown in column 4 of the first table to allow for a hidden vehicle approaching at speed
- (ii) When used on high-speed dual carriageway roads:  
Diagram 510 "Roundabout ahead" - see para 2.14  
Diagram 520 "Dual carriageway ends ahead" - see paras 5.1 to 5.8  
Diagram 521 "Two-way traffic" - see paras 5.1 to 5.8
- (iii) When used on any road:  
Diagram 522 "Two-way traffic on route crossing ahead" - see para 5.4  
Diagram 558 "Low-flying aircraft" - see para 14.2.

6. The combined metric/imperial height restriction warning triangle (diagram 530A) incorporated into a directional sign or the sign to diagram 818.5 (see figure 7-3 in this chapter and Appendix D in Chapter 7) is 30 stroke widths in height. The combined metric/imperial height restriction roundel (diagram 629.2A) incorporated into a directional sign or a sign to diagram 818.3 or 818.4 (see figure 7-2 in this chapter and Appendix D in Chapter 7) is 30 stroke widths in diameter. The table below sets out recommended x-heights and corresponding triangle heights and roundel diameters for the signs to diagrams 818.3, 818.4 and 818.5, appropriate to various 85th percentile speeds. The dimensions in brackets apply where motorways and all-purpose dual carriageway roads have three or more lanes per carriageway. For appropriate x-heights for directional signs, see Appendix A in Local Transport Note 1/94, available from TSO or [www.gov.uk/government/publications/local-transport-notes](http://www.gov.uk/government/publications/local-transport-notes).

| 85th percentile speed<br>of private cars<br>(mph) | x-height<br>(mm) | Triangle height /<br>roundel diameter<br>(mm) |
|---|------------------|---|
| Up to 20  | 60               | 450   |
| 21 to 30  | 80               | 600   |
| 31 to 40  | 100              | 750   |
| 41 to 50  | 120              | 900   |
| 51 to 60  | 160              | 1200  |
| 61 to 70  | 200              | 1500  |
| 70 mph speed limit                                | 240 (300)        | 1800 (2250)                                   |

7. 85th percentile speed measurement is dealt with in TA22 "Vehicle speed measurement on all-purpose roads" in Volume 5 of the Design Manual for Roads and Bridges (see para 1.3). The dry weather spot speed should be used.

## B APPENDIX

### SIZES OF SUPPLEMENTARY PLATES

| Diagram No.        | Description   | x-height or plate size (mm) appropriate to the triangle heights shown (see Appendix A) |                          |             |                           |                           |
|--------------------|---|--|--------------------------|-------------|---------------------------|---------------------------|
|                    |   | 600 <sup>1</sup><br>(mm)   | 750 <sup>1</sup><br>(mm) | 900<br>(mm) | 1200 <sup>2</sup><br>(mm) | 1500 <sup>3</sup><br>(mm) |
| 502                | STOP 'x' yds  | 62.5   | 75                       | 100         | 125                       | -                         |
| 503                | GIVE WAY 'x' yds                                      | 62.5   | 75                       | 100         | 125                       | -                         |
| 511                | REDUCE SPEED NOW                                      | 62.5   | 75                       | 100         | 125/150                   | 200                       |
| 513.1              | Adverse camber  | 50/62.5  | 75                       | 100         | 125                       | 150                       |
| 513.2              | Maximum speed advised                                 | 50*/62.5   | 75                       | 100         | 125                       | -                         |
| 518                | Single file traffic                                   | 50/62.5  | 75                       | 100         | 125                       | 150                       |
| 519                | Single track road                                     | 50/62.5  | 75                       | 100         | -                         | -                         |
| 525                | Low gear now  | 50/62.5  | 75                       | 100         | 125                       | 150                       |
| 526                | Keep in low gear                                      | 50/62.5  | 75                       | 100         | 125                       | 150                       |
| 527                | Low gear for 'x' miles                                | 50/62.5  | 75                       | 100         | 125                       | 150                       |
| 530.1              | Overhanging building<br>(when used with diagram 530)  | 50*/62.5   | 75                       | 100         | -                         | -                         |
| 530.1              | Overhanging building<br>(when used with diagram 530A) | -  | 50*/62.5                 | 75          | 100                       | -                         |
| 531.2              | ARCH BRIDGE High vehicles use middle of road          | -  | 75                       | 100         | 125/150                   | -                         |
| 543.1              | Part time signals                                     | 50/62.5  | 75                       | 100         | 125                       | 150                       |
| 546                | School  | 50/62.5  | 75                       | 100         | 125/150                   | -                         |
| 547.1              | Patrol  | 62.5/75  | 100                      | 125         | 150                       | -                         |
| 547.2              | Playground  | 50/62.5  | 75                       | 100         | 125/150                   | -                         |
| 547.3              | No footway for 'x' yds                                | 50/62.5  | 75                       | 100         | 125/150                   | -                         |
| 547.4              | Disabled people                                       | 50/62.5  | 75                       | 100         | 125/150                   | -                         |
| 547.7              | Disabled children                                     | 50/62.5  | 75                       | 100         | 125/150                   | -                         |
| 547.8 <sup>4</sup> | Humped crossing                                       | 50/62.5  | 75                       | 100         | 125                       | -                         |
| 548.1              | When lights show 'x' yds                              | 50/62.5  | 75                       | 100         | 125                       | 150                       |
| 553                | Horse-drawn vehicles and animals                      | 50*/62.5   | 75                       | 100         | -                         | -                         |
| 553.2              | Farm traffic  | 50/62.5  | 75                       | 100         | 125/150                   | 150                       |
| 554.3              | Ice<br>Snowdrifts                                     | 62.5/75<br>62.5  | 100<br>75                | 125<br>100  | 150<br>125                | 200<br>150                |
| 556.2              | Soft verges for 'x' miles                             | 50*/62.5   | 75                       | 100         | 125                       | 150                       |

| Diagram No.      | Description   | x-height or plate size (mm) appropriate to the triangle heights shown (see Appendix A) |                          |             |                           |                           |
|------------------|---|--|--------------------------|-------------|---------------------------|---------------------------|
|                  |   | 600 <sup>1</sup><br>(mm)   | 750 <sup>1</sup><br>(mm) | 900<br>(mm) | 1200 <sup>2</sup><br>(mm) | 1500 <sup>3</sup><br>(mm) |
| 557.2            | Humps for 'x' miles   | 50   | -                        | -           | -                         | -                         |
| 557.3            | Humps for 'x' yards in the direction indicated                          | 50*/62.5   | 75                       | 100         | 125                       | -                         |
| 557.4            | Hump 'x' yards in the direction indicated                               | 50*/62.5   | 75                       | 100         | 125                       | -                         |
| 558.2            | Gliders   | 50/62.5  | 75                       | 100         | 125/150                   | 150                       |
| 563              | Accident  | 62.5   | 75                       | 100         | 125/150                   | 200                       |
| 563.1            | FIRE STATION STOP when lights show (x- ht of lower case legend)         | 62.5   | 75                       | 100         | 100                       | -                         |
| 570              | For 'x' miles   | 50/62.5  | 75                       | 100         | 125/150                   | 200                       |
| 572 <sup>5</sup> | 'x' yds (when used with diagram 530A or 531.1)                          | -  | 50/62.5                  | 75          | 100                       | 125/150                   |
| 572 <sup>5</sup> | 'x' yds (when used with other warning signs)                            | 50/62.5  | 75                       | 100         | 125/150                   | 200                       |
| 573 <sup>5</sup> | Distance and direction to hazard (when used with diagram 530A or 531.1) | -  | 50/62.5                  | 75          | 100                       | 125/150                   |
| 573 <sup>5</sup> | Distance and direction to hazard (when used with other warning signs)   | 50/62.5  | 75                       | 100         | 125/150                   | 200                       |
| 575              | Oncoming vehicles in middle of road                                     | 50/62.5  | 75                       | 100         | 125                       | 150                       |
| 583.1            | Slow lorries for 'x' miles  | 50/62.5  | 75                       | 100         | 125/150                   | 200                       |
| 584.1            | Queues likely   | 50/62.5  | 75                       | 100         | 125/150                   | 200                       |
| 773              | STOP when lights show (x-height of lower case legend)                   | 62.5   | 75                       | 100         | 125                       | -                         |
| 778              | Train symbol (plate size)   | 440 x 420  | 550 x 525                | 660 x 630   | 660 x 630                 | -                         |
| 778.1            | Tram symbol ( plate size)   | 480 x 300  | 600 x 375                | 720 x 450   | 720 x 450                 | -                         |
| 780A             | Safe height   | 50/62.5  | 75                       | 100         | 125                       | -                         |
| 780.1A           | Safe height at distance and in direction indicated                      | 50/62.5  | 75                       | 100         | 125                       | -                         |
| 780.2A           | Safe height and load gauge  | 50/62.5  | 75                       | 100         | 125                       | -                         |

| Diagram No. | Description                                   | x-height or plate size (mm) appropriate to the triangle heights shown (see Appendix A) |                          |             |                           |                           |
|-------------|---|--|--------------------------|-------------|---------------------------|---------------------------|
|             |   | 600 <sup>1</sup><br>(mm)   | 750 <sup>1</sup><br>(mm) | 900<br>(mm) | 1200 <sup>2</sup><br>(mm) | 1500 <sup>3</sup><br>(mm) |
| 817.2       | Escape lane ahead                             | 50*/62.5   | 75                       | 100         | 125                       | 125                       |
| 950.1       | Child cycle tests                             | 50*/62.5   | 75                       | 100         | -                         | -                         |
| 7009.1      | Skid risk and maximum advised speed of 20 mph | 50*/62.5   | 75                       | 100         | 125                       | -                         |

## NOTES

1. For the 600 mm and 750 mm size triangles, the smaller x-height, where more than one is shown, is appropriate if the 85th percentile speed is 20 mph or less. Where a 50 mm x-height is marked with an asterisk, this is the standard size for 85th percentile speeds up to 30 mph.
2. For the 1200 mm size triangle, the larger x-height, where more than one is shown, should be used on dual carriageway roads where the national speed limit applies or on single carriageway roads where greater emphasis is required.
3. As a 1500 mm size sign is sometimes used in place of a 1200 mm sign (see note 2 of Appendix A), x-heights for supplementary plates used in these circumstances are quoted even though that particular sign may not be used on motorways or all-purpose dual carriageways with grade separated junctions. The larger x-height, where more than one is shown, should be used on dual carriageway roads where the national speed limit applies or on single carriageway roads where greater emphasis is required.
4. The larger signs are intended for use on main roads when an arrow has been added to the plate indicating a humped pedestrian crossing in the minor road leading from the junction ahead.
5. Although permitted by the Regulations, diagrams 530 and 530A are unlikely to be used with the supplementary plates to diagrams 572 and 573 (see section 7).

## VARIATION OF NUMERALS AS PRESCRIBED BY SCHEDULE 16 TO THE REGULATIONS

| Diagram No. | Description  | Item(s) in Schedule 16 | Permitted variant  |  |
|-------------|--|------------------------|--|--|
| 502         | STOP 100 yds   | 6                      | Item 1 Numerals may be varied but (with the exception of one decimal place of a metre indicating a height, width or length) no fractions or decimal places shall be used.  |  |
| 503         | GIVE WAY 50 yds  | 6                      |  |  |
| 513.2       | Maximum speed advised  | 1                      |  |  |
| 518         | Single file traffic (when distance is added)   | 6                      |  |  |
| 519         | Single track road (when distance is added)   | 6                      |  |  |
| 523.1       | Steep hill downwards   | 1                      |  |  |
| 524.1       | Steep hill upwards   | 1                      |  |  |
| 527         | Low gear for 1½ miles  | 5                      |  |  |
| 530         | Maximum headroom   | 1                      |  |  |
| 530A        | Single sign showing available headroom in both metric and imperial units                 | 1                      |  | Item 5 Numerals indicating distance may be varied with distances being expressed in miles except that fractions ¾, ½ and ¼ may be used for distances of less than 3 miles. |
| 530.1       | Overhanging building (when distance is added)  | 6                      |  |  |
| 531.1       | Maximum headroom at arch bridge  | 1                      |  |  |
| 532.2       | Maximum headroom at centre of arch bridge  | 1                      |  |  |
| 532.2A      | Maximum headroom at centre of arch bridge indicated by a sign to diagram 530A            | 1                      |  |  |
| 532.3       | Maximum headroom at centre and side of arch bridge                                       | 1                      |  |  |
| 532.3A      | Maximum headroom at side and in centre of arch bridge indicated by signs to diagram 530A | 1                      |  |  |
| 543.1       | Part time signals (when distance is added)   | 6                      |  |  |
| 546         | School (when distance is added)  | 6                      |  |  |
| 547.1       | Patrol (when distance is added)  | 6                      | Item 6 Numerals indicating distance may be varied with:<br><br>(a) distances over 3 miles being expressed in miles to the nearest mile;<br><br>(b) distances of ½ mile or more but less than 3 miles being expressed to the nearest ¼ mile with the fractions ¾, ½ and ¼ being used; and<br><br>(c) distances of less than ½ mile being expressed in yards to the nearest 10 yards; "yards" or the abbreviation "yds" may be used interchangeably.<br><br>Where a sign includes a distance expressed in miles, the words "mile" or "miles" may be used as appropriate. |  |
| 547.2       | Playground (when distance is added)  | 6                      |  |  |
| 547.3       | No footway for 400 yds   | 6                      |  |  |
| 547.4       | Disabled people (when distance is added)   | 6                      |  |  |
| 547.7       | Disabled children (when distance is added)   | 6                      |  |  |
|             |  |                        |  | Item 9 The indication of distance may be omitted from the sign.  |
|             |  |                        |  |  |



| Diagram No.         | Description   | Item(s) in Schedule 16 | Permitted variant  |
|---------------------|---|------------------------|--|
| 547.8               | Humped crossing (when distance is added)  | 6                      | Item 10 The indication of distance may be replaced by an arrow pointing horizontally to the left or to the right as appropriate. |
| 548.1               | When lights show 200 yds  | 6                      |  |
| 553.2               | Farm traffic (when distance is added)   | 6                      |  |
| 554.3               | Ice (when distance is added)  | 6                      |  |
| 556.2               | Soft verges for 2 miles   | 6                      |  |
| 557.2               | Humps for ½ mile  | 6                      |  |
| 557.3               | Humps for 300 yards   | 6                      |  |
| 557.4               | Hump 20 yds   | 6, 9                   |  |
| 558.2               | Gliders (when distance is added)  | 6                      |  |
| 563                 | Accident (when distance is added)   | 6                      |  |
| 563.1               | FIRE STATION STOP when lights show (when distance is added)                                 | 6                      |  |
| 570                 | For 2 miles   | 6                      |  |
| 572                 | 400 yds   | 6                      |  |
| 573                 | Distance and direction to hazard  | 6, 9                   |  |
| 583.1               | Slow lorries for 2 miles  | 5                      |  |
| 629.2               | Mandatory height restriction (imperial units)   | 1                      |  |
| 629.2A              | Mandatory height restriction (metric and imperial units)                                    | 1                      |  |
| 773                 | STOP when lights show (when distance is added)  | 6                      |  |
| 780A <sup>1</sup>   | Safe height 16'-6" (5.0m)   | 1                      |  |
| 780.1A <sup>1</sup> | Safe height 15'-6" (4.7m) 150yds  | 1, 6, 9                |  |
| 780.2A <sup>1</sup> | Safe height 15'-6" (4.7m) load gauge  | 1                      |  |
| 817.2               | Escape lane ahead (when distance is added)  | 6                      |  |
| 818.1 <sup>2</sup>  | Dual carriageway 2 miles ahead  | 6                      |  |
| 818.3               | Mandatory height limit at low bridge ahead <sup>3</sup>                                     | 1, 6, 10               |  |
| 818.4               | Mandatory height limit at low bridge ahead and indication of alternative route <sup>4</sup> | 1, 6                   |  |
| 818.5               | Available headroom at low bridge ahead and indication of alternative route <sup>5</sup>     | 1, 6                   |  |

---

| Diagram No. | Description                                | Item(s) in Schedule 16 | Permitted variant |
|-------------|--|------------------------|-------------------|
| 950.1       | Child cycle tests (when distance is added) | 6                      |                   |

## NOTES

1. The metric dimension (but not the imperial) may be omitted from diagrams 780A, 780.1A and 780.2A.
2. The maximum distance permitted on diagram 818.1 is 2 miles.
3. Permitted variant 1 applies to the height restriction. When permitted variant 10 applies, the word "ahead" is omitted.
4. Permitted variant 1 applies to the height restriction. Permitted variant 6 applies when a distance is added.
5. Permitted variant 1 applies to the available headroom. Permitted variant 6 applies when a distance is added.

# D APPENDIX

---

## SCHEDULE OF DIAGRAM NUMBERS

|        |   |       |   |
|--------|---|-------|---|
| 501    | 2.1, 2.2, 5.15  | 543   | 8.1, 8.3 - 8.6, 9.1, 9.13, 20.5, 22.1             |
| 502    | 2.1, 5.15   | 543.1 | 8.5, 18.1   |
| 503    | 2.1, 5.15   | 544   | 9.1 - 9.3, 9.13                                   |
| 504.1  | 1.12, 2.2, 2.3, 5.14                                    | 544.1 | 9.4   |
| 505.1  | 1.12, 2.2, 2.3  | 544.2 | 9.5, 9.6  |
| 506.1  | 1.12, 2.2, 2.3, 2.5, 5.14                               | 545   | 9.7 - 9.11  |
| 507.1  | 1.12, 2.2 - 2.5   | 546   | 9.7, 9.8, 9.11, 18.1                              |
| 508.1  | 2.8, 2.9  | 547.1 | 9.7, 9.8, 9.10, 9.11, 18.1                        |
| 509.1  | 2.8, 2.9  | 547.2 | 9.7, 18.1   |
| 510    | 1.12, 2.13 - 2.15, 5.7, 20.5,<br>Appendix A             | 547.3 | 9.4, 9.7, 9.9                                     |
| 511    | 2.13, 2.14, 2.17, 3.12, 4.1, 12.1                       | 547.4 | 9.6, 18.1   |
| 512    | 1.12, 3.1, 3.11, 3.18, 19.3                             | 547.7 | 9.7, 9.8, 9.11, 18.1                              |
| 512.1  | 1.12, 3.6, 3.11, 19.3                                   | 547.8 | 9.13, 18.1  |
| 512.2  | 1.12, 3.6, 3.11, 19.3                                   | 548   | 10.4, 10.5  |
| 513    | 1.12, 3.7, 3.11, 19.3                                   | 548.1 | 10.5  |
| 513.1  | 2.13, 3.9   | 549   | 10.10   |
| 513.2  | 3.10 - 3.12, 12.4                                       | 550   | 10.10, 10.11                                      |
| 515    | 3.8, 3.13, 3.15, 3.22, 3.23, 11.9                       | 550.1 | 10.11, 10.12                                      |
| 515.1  | 3.22  | 550.2 | 10.11   |
| 515.1A | 3.22, 3.23  | 551   | 10.10   |
| 515.2  | 3.23  | 551.1 | 1.43, 10.13                                       |
| 516    | 4.1, 4.3, 7.2, 16.4, 19.3                               | 551.2 | 10.14   |
| 517    | 4.1, 4.3, 7.2, 16.4, 19.3,<br>Appendix A                | 552   | 10.15   |
| 518    | 4.4, 18.1   | 553   | 10.15   |
| 519    | 4.4, 18.1   | 553.1 | 10.16   |
| 520    | 4.1, 5.1, 5.5, 5.7, Appendix A                          | 553.2 | 10.16, 18.1                                       |
| 521    | 4.1, 5.1 - 5.3, 5.5, 5.7, Appendix A                    | 554   | 1.43, 10.17, 11.1, 11.2                           |
| 522    | 5.1, 5.4, Appendix A                                    | 554.1 | 6.6, 6.9, 11.2                                    |
| 523.1  | 6.1, 6.2, 6.6, 6.9                                      | 554.2 | 1.43, 11.7, 11.8                                  |
| 524.1  | 6.1, 6.10   | 554.3 | 11.7, 18.1  |
| 525    | 6.3, 6.9, 6.11  | 555   | 11.9, 11.10                                       |
| 526    | 6.3, 6.6, 6.9, 6.11                                     | 555.1 | 11.10   |
| 527    | 6.3, 6.11   | 556   | 1.43, 12.1  |
| 528    | 7.1, 19.3   | 556.1 | 12.2  |
| 528.1  | 7.2, 16.4   | 556.2 | 12.2  |
| 529    | 7.3, 21.3   | 557   | 1.43, 12.3  |
| 529.1  | 7.4, 7.5, 19.3, 21.3                                    | 557.1 | 13.1  |
| 530    | 7.18, 7.19, 7.22, 7.29, Appendix A,<br>Appendix B       | 557.2 | 13.5  |
| 530A   | 7.14, 7.18, 7.19, 7.22, 7.29,<br>Appendix A, Appendix B | 557.3 | 13.5  |
| 530.1  | 7.29, 18.1  | 557.4 | 13.5  |
| 530.2  | 7.7, 7.20, 7.26   | 558   | 14.1, 14.2, 21.3, Appendix A                      |
| 531.1  | 7.22 - 7.24   | 558.1 | 14.3  |
| 531.2  | 7.22, 7.24, 19.3  | 558.2 | 14.1, 14.2, 18.1                                  |
| 532.2  | 7.16, 7.23, 7.24  | 559   | 15.1  |
| 532.2A | 7.16, 7.23, 7.24  | 560   | 1.21, 4.2, 11.9, 16.1                             |
| 532.3  | 7.16, 7.23, 7.24  | 561   | 1.21, 4.2, 11.9, 16.1                             |
| 532.3A | 7.16, 7.23, 7.24  | 562   | 1.43, 9.1, 17.1                                   |
|        |   | 563   | 1.43, 9.1, 11.1, 17.2 - 17.4, 18.1,<br>Appendix A |
|        |   | 563.1 | 8.2, 17.2, 17.5, 18.1                             |

---

|        |  |                       |  |
|--------|--|-----------------------|--|
| 570    | 3.8, 6.10, 10.3, 10.13, 10.14,<br>10.17, 12.1, 12.3, 14.2, 15.1, 18.2,<br>18.3, 19.5                 | 783<br>784.1<br>785.1 | 21.14, 21.20<br>21.14, 21.20<br>21.14, 21.20 |
| 572    | 1.20, 2.5, 2.12, 2.13, 2.15, 8.3,<br>9.2, 10.11, 10.15, 10.17, 11.1,<br>11.2, 18.4, 22.1, Appendix B | 786<br>787<br>788     | 21.15, 21.20<br>21.16<br>21.16, 21.20        |
| 573    | 8.1, 9.2, 10.11, 10.15, 10.17, 11.1,<br>11.2, 18.5, 22.1, Appendix B                                 | 789<br>789.1          | 21.17<br>21.17                               |
| 574    | 1.19, 1.43, 19.1, 19.2   | 789.2                 | 21.17  |
| 575    | 4.2, 19.3  | 790                   | 1.11, 21.19                                  |
| 581    | 19.4   | 817.2                 | 6.9  |
| 582    | 20.1   | 818                   | 5.9  |
| 583    | 6.12, 20.3   | 818.1                 | 5.10   |
| 583.1  | 6.12, 20.3   | 818.1A                | 5.9  |
| 584    | 20.5   | 818.3                 | 7.13, 7.18, Appendix A                       |
| 584.1  | 20.5   | 818.4                 | 7.13, 7.15, 7.18, Appendix A                 |
| 601.1  | 2.3, 21.8  | 818.5                 | 7.13, 7.16, 7.22, Appendix A                 |
| 602    | 2.3, 21.8  | 821                   | 4.5  |
| 606    | 3.19, 3.20, 3.23, 5.17   | 822                   | 4.5  |
| 608    | 2.1, 5.15, 5.17  | 823                   | 2.18   |
| 609    | 5.17   | 824                   | 2.18   |
| 610    | 5.12, 23.3   | 825                   | 2.18   |
| 611.1  | 2.16   | 826                   | 11.5, 11.6                                   |
| 612    | 5.14   | 826.1                 | 11.5, 11.6                                   |
| 616    | 5.13, 5.16   | 868                   | 2.8  |
| 622.1A | 11.8   | 868.1                 | 2.8  |
| 622.4  | 11.8   | 872.1                 | 4.6, 4.7                                     |
| 629    | 11.8   | 873                   | 2.8  |
| 629A   | 11.8   | 874                   | 2.8  |
| 629.1  | 11.8   | 875                   | 2.8  |
| 629.2  | 7.18   | 876                   | 2.8  |
| 629.2A | 7.18, Appendix A   | 950                   | 22.1, 22.2                                   |
| 632    | 11.8   | 950.1                 | 18.1, 22.1, 22.2                             |
| 674    | 13.1   | 1010                  | 2.8  |
| 770    | 21.2, 21.17  | 1013.1                | 19.3   |
| 771    | 21.2, 21.17  | 1024                  | 2.1  |
| 772    | 21.2, 21.17  | 1028.3                | 21.15  |
| 773    | 7.3, 7.4, 8.2, 14.1, 14.2, 18.1, 21.3  | 1038                  | 5.2  |
| 774    | 21.4, 21.5, 21.20  | 1046                  | 5.13, 5.16                                   |
| 775    | 21.5, 21.20  | 2002                  | 7.14   |
| 776    | 21.6   | 2003                  | 7.14   |
| 777    | 21.7, 21.20  | 2024                  | 2.16   |
| 778    | 21.8   | 2027                  | 7.14   |
| 778.1  | 21.8   | 2107                  | 7.14   |
| 779    | 21.9, 21.12  | 2108                  | 7.14   |
| 780A   | 21.10  | 2119                  | 2.16   |
| 780.1A | 21.10  | 2120                  | 2.16   |
| 780.2A | 21.10, 21.12   | 2401                  | 7.5  |
| 781    | 21.10, 21.11   | 2928                  | 7.5  |
| 782    | 7.1, 12.1, 21.13   | 3014                  | 7.3, 8.2, 17.5, 21.3, 21.8                   |

---

|        |   |
|--------|---|
| 4004   | 9.7, 9.11                                 |
| 4005   | 10.4                                      |
| 7009   | 3.11, 12.4                                |
| 7009.1 | 12.4                                      |
| 7010.1 | 1.43, 8.8, 11.2                           |
| 7014   | 1.11, 1.17, 1.43, 2.19, 5.14,<br>8.7, 9.1 |
| 7014.1 | 1.18, 1.43, 7.9                           |
| 7019   | 8.8                                       |
| 7022   | 17.2                                      |
| 7030   | 8.6                                       |

# INDEX

---

|                           |   |   |                                     |
|---------------------------|---|---|-------------------------------------|
| Adverse camber            | 3.9, 3.10   | Countdown markers<br>at level crossings | 2.18<br>21.17                       |
| Advisory speed            | 3.11, 12.4  | Cycling                                 | 22.1, 22.2                          |
| Agricultural vehicles     | 10.16   | Depth gauges                            | 11.5, 11.6                          |
| Aircraft                  | 14.1 - 14.3   | Design Manual<br>for Roads and Bridges  | 1.3, 1.39, 4.3, 8.6, 10.7,<br>12.3  |
| Ambulance station         | 17.5  | Disabled pedestrians                    | 9.5, 9.6, 9.8                       |
| Animal disease            | 1.19, 19.1, 19.2  | Distance plates                         | 18.1 - 18.6                         |
| Animals                   | 10.1 - 10.15, 18.2, 18.3  | <i>see also individual sections</i>     |                                     |
| Arch bridges              | 7.6, 7.7, 7.16, 7.21 - 7.24                                     | Dual carriageways                       | 5.1 - 5.2, 5.5 - 5.17               |
| Backing boards            | 1.32 - 1.34, 1.42, 3.15   | ahead                                   | 5.9 - 5.12                          |
| Bends                     | 3.1 - 3.9, 3.11 - 3.13, 19.3                                    | bends                                   | 3.4                                 |
| Bridges                   | 7.1 - 7.3, 7.6 - 7.27   | end                                     | 5.1, 5.2, 5.5 - 5.8                 |
| abutments                 | 7.2, 16.4   | gap closures                            | 5.14                                |
| arch                      | 7.6, 7.7, 7.16, 7.21 - 7.24                                     | hazard markers                          | 16.1                                |
| composite                 | 7.25 - 7.27   | lane loss                               | 4.6 - 4.8                           |
| diversion signing         | 7.13 - 7.16, 7.18   | low bridges                             | 7.7                                 |
| hump                      | 7.1, 19.3   | queues likely                           | 20.7                                |
| low                       | 7.6 - 7.27  | roundabouts                             | 2.14, 2.18, 5.7, 5.13               |
| non-arch                  | 7.13, 7.17 - 7.20   | side roads                              | 2.1, 5.15 - 5.17                    |
| opening                   | 7.3   | End of one-way road                     | 5.3, 5.4                            |
| parapets                  | 7.2, 16.4   | Escape lanes                            | 6.6, 6.9                            |
| reduced headroom          | 1.18, 1.43, 7.9   | Falling rocks                           | 15.1                                |
| Cattle                    | 10.1 - 10.9   | Farm traffic                            | 10.16                               |
| grids                     | 10.15   | Fire station                            | 17.5                                |
| Chevron signs             | 3.13 - 3.23, 11.9   | Flashing amber lamps                    |                                     |
| backing boards            | 3.15  | cattle crossing                         | 10.4 - 10.9                         |
| flexible                  | 3.22  | children crossing                       | 9.11, 9.12                          |
| paved                     | 3.23  | Fluorescent materials                   | 1.33, 7.2, 7.6, 7.20,<br>7.24, 7.27 |
| Children                  | 9.7 - 9.12  | Flood                                   | 11.1, 11.2, 11.5, 11.10             |
| Chord marking             | 1.38, 7.7, 7.23, 7.24   | Ford                                    | 11.1, 11.3 - 11.6                   |
| Clear visibility distance | 1.22, 1.23, 1.41, 2.1,<br>2.16                                  | Frail pedestrians                       | 9.5, 9.6                            |
| Climbing lanes            | 4.3   | Gap closures                            | 5.14                                |
| Conspicuity               | 1.15, 1.32 - 1.35, 1.39,<br>1.40, 3.15, 7.2, 7.6,<br>7.20, 16.3 | Gates                                   | 10.17                               |

---

---

|                                  |   |                           |   |
|----------------------------------|---|---------------------------|---|
| Give Way signs                   | 1.28, 2.1, 2.3, 5.15                              | Maintenance               | 1.22, 1.23, 1.39 - 1.42,<br>3.23, 7.2, 7.6, 21.14                     |
| Gliders                          | 14.1, 14.2  | Mandatory height limits   | 7.14, 7.15, 7.17 - 7.19,<br>7.21                                      |
| Hazard markers                   | 11.9, 16.1 - 16.7                                 | Maximum speed advised     | 3.10, 3.11, 12.4  |
| Headroom                         |   | Merge signing             | 2.8 - 2.12  |
| bridges                          | 1.18, 1.43, 7.6 - 7.12,<br>7.16, 7.18, 7.24, 7.26 | Metric distances          | 18.6  |
| measurement                      | 7.8 - 7.12  | Metric heights            | 7.8, 7.12, 7.18, 21.10  |
| metric heights                   | 7.8, 7.12, 7.18, 21.10                            | Metric units              | 7.8, 7.12, 7.18, 11.6,<br>18.6, 21.10                                 |
| signs                            | 1.24  | Military vehicles         | 20.1, 20.2  |
| Helicopters                      | 14.3  | Miscellaneous hazards     | 17.1 - 17.5, 19.1 - 19.5  |
| Hills                            | 6.1 - 6.12, 20.3, 20.4                            | Mounting                  | 1.24 - 1.31   |
| Horse-drawn vehicles             | 10.1 - 10.3, 10.11                                | backing boards            | 1.32 - 1.34   |
| Horses                           |   | chevrons                  | 3.15, 3.19  |
| accompanied                      | 10.1 - 10.3, 10.11, 10.12                         | hazard markers            | 16.2  |
| wild                             | 10.1 - 10.3, 10.10                                | height                    | 1.24, 1.30, 1.31  |
| Humps                            | 13.1 - 13.6                                       | multiple signs            | 1.27 - 1.31   |
| humped crossings                 | 9.13, 13.6  | order                     | 1.28, 1.29, 6.9, 7.1  |
| Ice                              | 11.7, 11.8  | New level crossing ahead  | 1.11, 21.19   |
| Illumination                     | 1.31, 1.35 - 1.40                                 | New road layout ahead     | 1.11, 1.17, 1.43  |
| <i>see also Reflectorisation</i> |   | New roundabout ahead      | 1.11, 1.17, 2.19  |
| Junctions                        | 2.1 - 2.19, 3.6, 3.13,<br>5.15 - 5.17             | New traffic signals ahead | 1.11, 1.17, 8.7   |
| Legibility                       | 1.14, 1.16, 1.31, 1.34,<br>1.39, 1.40, 3.15       | New Zebra crossing ahead  | 1.11, 1.17, 9.1   |
| Level crossings                  | 9.11, 12.1, 21.1 - 21.20                          | Non-arch bridges          | 7.13, 7.17 - 7.20   |
| Lighting                         | 1.31, 1.35 - 1.38                                 | No smoking                | 11.2  |
| Load gauge                       | 21.11, 21.12                                      | Obscuration               | 1.21 - 1.23, 1.32, 1.34,<br>1.41, 3.21, 8.2, 8.3, 9.3,<br>11.10, 23.1 |
| Long vehicles                    | 7.1, 7.10, 21.13 - 21.16                          | Obsolete signs            | 1.11, 1.43  |
| Lorries                          | 3.10, 20.3, 20.4                                  | Older drivers             | 1.27, 1.40  |
| Loose chippings                  | 12.4  | Oncoming vehicles         | 4.2, 19.3   |
| Low bridges                      | 7.6 - 7.27  | Opening bridge            | 7.3   |
| Low-flying aircraft              | 14.1 - 14.3                                       |                           |   |

---

|                       |   |                       |  |
|-----------------------|---|-----------------------|--|
| Overhanging buildings | 7.29  | Refuge beacon         | 23.1 - 23.4  |
| Overhead power cables | 21.9 - 21.12  | Risk of grounding     | 7.1, 21.13   |
| Overload              | 1.27  | River banks           | 11.9, 11.10  |
| Part time signals     | 8.5   | Road humps            | 13.1 - 13.6  |
| Passing place         | 4.5   | Road narrows          | 4.1 - 4.8, 7.2, 16.4, 19.3                                     |
| Peak hour signals     | 8.5   | Road surface          | 12.1, 12.3, 12.4   |
| Pedestrians           | 9.1 - 9.13, 17.4  | Roundabouts           | 2.13 - 2.19, 3.10, 3.13,<br>3.19 - 3.23, 5.7, 5.13             |
| blind                 | 9.5, 9.6, 9.8   | Secretary of State    | 1.2, 1.5, 5.13, 5.16,<br>10.13                                 |
| children              | 9.7 - 9.12  | Sheep                 | 10.1 - 10.3, 10.10, 18.2                                       |
| frail or disabled     | 9.5, 9.6, 9.8   | Side roads            | 2.1, 5.3, 5.15 - 5.17  |
| humped crossings      | 9.13, 13.6  | Side winds            | 19.4, 19.5   |
| in road               | 9.4, 9.7, 9.9, 17.3, 17.4   | Signalled roundabouts | 8.4, 8.5   |
| Pelican crossings     | 8.1 - 8.3, 9.1, 9.10, 9.11,<br>9.13, 13.6, 17.4                                     | Signalled crossings   | 8.1 - 8.3, 9.1, 9.10, 9.11,<br>9.13, 13.6, 17.4                |
| Puffin crossings      | 8.1 - 8.3, 9.1, 9.10, 9.11,<br>17.4   | Single file traffic   | 4.4  |
| Toucan crossings      | 8.1 - 8.3, 9.1, 9.10, 9.11,<br>17.4   | Single track road     | 4.4, 4.5   |
| Zebra crossings       | 9.1 - 9.3, 9.10, 9.11,<br>9.13, 13.6, 17.4, 23.4                                    | Siting                | 1.20 - 1.23, Appendix A<br><i>see also individual sections</i> |
| Pelican crossings     | 8.1 - 8.3, 9.1, 9.10, 9.11,<br>9.13, 13.6, 17.4                                     | Sizes of signs        | 1.13 - 1.18, Appendix A  |
| Police station        | 17.5  | arch bridges          | 7.22, 7.23   |
| Power cables          | 21.9 - 21.12  | chevron signs         | 3.16   |
| Priority junctions    | 2.2 - 2.7, 3.6, 3.13  | ice                   | 11.7   |
| dual carriageways     | 5.15 - 5.17   | level crossings       | 21.14, 21.20   |
| Puffin crossings      | 8.1 - 8.3, 9.1, 9.10, 9.11,<br>17.4   | loss of lane          | 4.7  |
| Quaysides             | 11.9, 11.10   | supplementary plates  | Appendix B   |
| Queues likely         | 20.5 - 20.7, 21.18  | Try your brakes       | 11.4   |
| Reduce speed now      | 2.14, 2.17, 3.12, 4.1,<br>12.1  | Skid risk             | 12.3, 12.4   |
| Reflectorisation      | 1.31, 1.33, 1.35 - 1.40,<br>3.23, 7.2, 7.6, 7.20,<br>7.23, 7.24, 7.27, 8.8,<br>16.5 | Slippery road         | 12.3   |
| Reference numbers     | 1.42  | Slip roads            | 2.8 - 2.12, 4.6, 5.13,<br>20.7                                 |

---



---

|  |  |                                     |  |
|--|--|-------------------------------------|--|
| Slow-moving vehicles<br>at level crossings<br>lorries  | 20.1 - 20.7<br>21.14<br>20.3, 20.4   | Two-way traffic                     | 5.1 - 5.8  |
| Snow   | 11.7, 11.8   | Uneven road                         | 12.1   |
| Soft verges  | 12.2   | Variants of numerals                | Appendix C   |
| Special authorisation<br>adverse camber<br>merge signs<br>tram crossing<br>tunnel length signs | 1.5<br>3.10<br>2.11<br>21.8<br>7.5   | Vehicle-activated signs             | 1.12   |
| Steep hills  | 6.1 - 6.12, 20.3, 20.4   | Verges                              | 12.2   |
| Stop signs   | 1.27, 2.1, 2.3, 5.15, 21.8   | Visibility                          | 1.21 - 1.23, 1.40, 1.41,<br>Appendix A                       |
| Supplementary plates   | 1.8, 1.16, 1.20, 1.24,<br>1.25, 1.27, 1.32,<br>Appendix B  | <i>see also individual sections</i> |  |
| <i>see also individual sections</i>  |  | Vulnerable pedestrians              | 9.4 - 9.6  |
| Tanks  | 20.1, 20.2   | Water                               | 11.1 - 11.10   |
| T-junctions  | 2.2, 3.13  | Watercourses                        | 11.9, 11.10  |
| Temporary signs  | 1.5, 1.11, 1.17, 1.18,<br>1.38, 1.43 - 1.45,<br>5.14, 7.9, 8.6 - 8.8,<br>10.13, 11.7, 11.8, 12.1,<br>12.3, 12.4, 17.1 - 17.3 | Wide vehicles                       | 10.16  |
| Toads  | 10.13  | Wig-wag signals                     | 7.3, 7.4, 8.2, 14.1, 14.2,<br>17.5, 21.3                     |
| Toucan crossings   | 8.1 - 8.3, 9.1, 9.10, 9.11,<br>17.4  | Wild animals                        | 10.1 - 10.3, 10.10, 18.3                                     |
| Tractors   | 10.16  | Wild fowl                           | 10.1 - 10.3, 10.14   |
| Traffic calming  | 13.1 - 13.6  | Wild horses                         | 10.1 - 10.3, 10.10   |
| Traffic signals<br>out of order<br>part time   | 8.1 - 8.8, 9.11<br>8.8<br>8.5  | Working drawings                    | 1.8, 1.16  |
| Trams  | 21.1 - 21.12   | <i>see also individual sections</i> |  |
| Try your brakes  | 6.6, 11.2 - 11.4   | x-height                            | 1.16 - 1.19, 1.25, 5.11,<br>21.14, Appendix A,<br>Appendix B |
| Tunnels  | 7.4, 7.5, 19.3   | Yellow backing boards               | 1.15, 1.32 - 1.34, 3.15                                      |
| Turning vehicles   | 10.16  | Zebra crossings                     | 9.1 - 9.3, 9.10, 9.11,<br>9.13, 13.6, 17.4, 23.4             |

---

*Warning Signs* explains the use of the warning signs prescribed by the Traffic Signs Regulations. It enables the correct sign to be used, and advises on the appropriate size and siting to ensure adequate warning of the hazard.



Published by TSO (The Stationery Office) and available from:

**Online**

**[www.tsoshop.co.uk](http://www.tsoshop.co.uk)**

**Mail, Telephone, Fax & E-mail**

TSO

PO Box 29, Norwich, NR3 1GN

Telephone orders/General enquiries: 0870 600 5522

Fax orders: 0870 600 5533

E-mail: [customer.services@tso.co.uk](mailto:customer.services@tso.co.uk)

Textphone 0870 240 3701

**TSO@Blackwell and other Accredited Agents**

£40.00

ISBN 978-0-11-553224-5



9 780115 532245